

INTEGRA

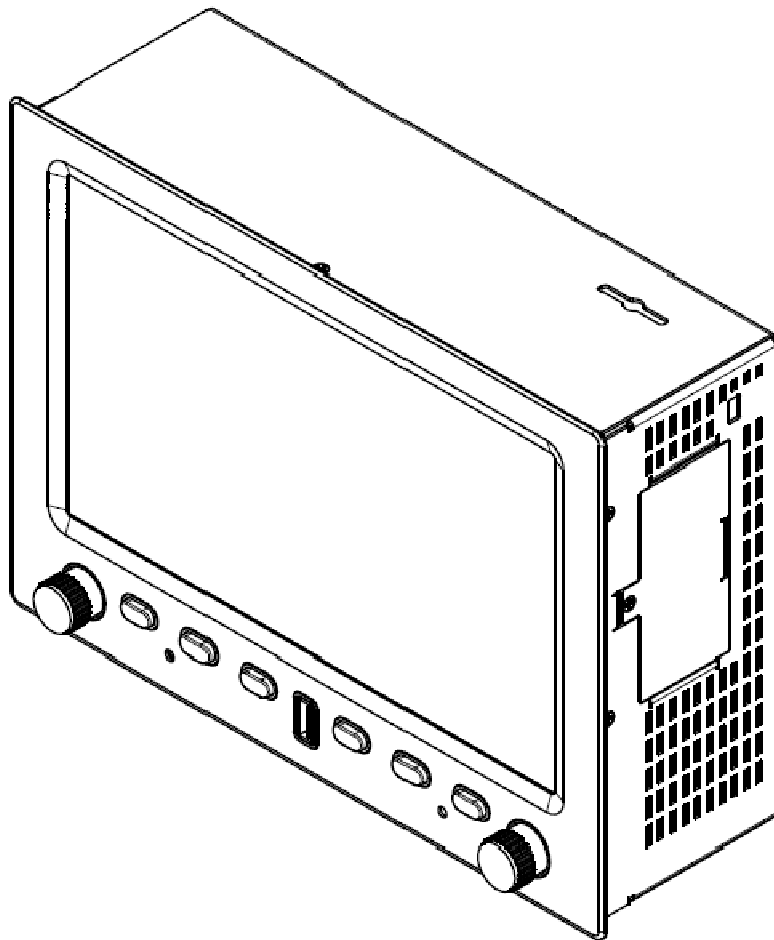

Installation Manual

TL-6660



P/N: TLX-6660X-DI-001-PrA

Copyright 2013
TL elektronik
All Rights Reserved

Except as expressly provided below, no part of this manual may be downloaded, transmitted, copied, reproduced, disseminated or stored in any storage medium, for any purpose without the express prior written consent of the TL elektronik company. Address your questions about the technical information to TL elektronik. Other information about sale, distribution should be directed to our exclusive distributors (see World Distributor list on our website).

Producer's address:
TL elektronik Inc.
Airport, Building 125,
503 41 Hradec Kralove, Czech Republic
Fax: +420 49 548 23 94 E-mail: info@tl-elektronik.com
Web Site Address: www.tl-elektronik.com

Please, send your e-mail address to customer@tl-elektronik.com to receive the latest information about software upgrade.

Send your ideas to innovation@tl-elektronik.com
We will evaluate your suggestion and provide an update.

Windows is registered trademark of Microsoft Corporation.
All trademarks and registered trademarks are acknowledged.
ScheckK® is registered trademark of TL elektronik.
iFamily® is registered trademark of TL elektronik.
sModern® is registered trademark of TL elektronik.

All information in this User's manual is subject to change without prior notice.

Table of contents

TABLE OF CONTENTS	II
1 REVISION TABLE	1-1
2 GENERAL DESCRIPTION	2-1
2.1 GENERAL INFORMATION.....	2-1
2.2 LIMITED WARRANTY.....	2-1
3 TECHNICAL SPECIFICATIONS	3-1
4 INSTALL RECOMMENDATION	4-1
4.1 INTRODUCTION.....	4-1
4.2 RACK CONSIDERATION.....	4-1
4.3 CALIBRATION AND TESTING OF STATIC PRESSURE MEASUREMENT FOR ALTITUDE DETERMINATION.....	4-1
4.4 INSTALLATION INTO PANEL.....	4-1
4.5 RECOMMENDED WIRING PRACTICES.....	4-3
4.6 THERMOCOUPLE HARNESS PREPARATION.....	4-3
4.7 HARNESS MATING.....	4-3
4.8 POWER REQUIREMENTS.....	4-3
4.9 WIRING OVERVIEW.....	4-3
4.10 GROUNDING.....	4-4
5 MECHANICAL DRAWING	5-1
5.1 FRONT VIEW.....	5-1
5.2 SIDE VIEW.....	5-1
5.3 REAR VIEW.....	5-2
5.4 FRONT VIEW OF MOUNTING RACK.....	5-2
5.5 SIDE VIEW OF THE MOUNTING RACK.....	5-3
5.6 PANEL CUTOUT.....	5-3
5.7 INTEGRA MOUNTING DIAGRAM.....	5-4
6 ELECTRICAL DRAWING	6-1
6.1 PIN FUNCTION LIST.....	6-1
6.1.1 <i>Power, Signalization, Transceiver and iFamily® Interconnect</i>	6-2
6.1.2 <i>Transponder Interconnect</i>	6-3
6.1.3 <i>Auxiliary Ports and iFamily® Interconnect</i>	6-5
6.1.4 <i>Auxiliary Input/Output Interconnect</i>	6-6
6.1.5 <i>IAT and OAT Interconnect</i>	6-7
6.1.6 <i>Position Interconnect</i>	6-8
6.1.7 <i>Engine RPM Interconnect</i>	6-9
6.1.8 <i>RPM and Temperature Sensor Interconnect</i>	6-11
6.1.9 <i>Volts and Shunt Sensor Interconnect</i>	6-12
6.1.10 <i>Fuel Sensors Interconnect - (Passive)</i>	6-13
6.1.11 <i>Fuel Sensors Interconnect - (Active)</i>	6-14
6.1.12 <i>Oil, Water/CHT Temperature and Oil Pressure - (Passive)</i>	6-15
6.1.13 <i>Oil, Water/CHT Temperature and Oil, Manifold Pressure - (Active)</i>	6-16
6.1.14 <i>Oil and Fuel Pressure - (Current Loop)</i>	6-17
6.1.15 <i>Thermocouples</i>	6-19
6.2 RECOMMENDED CONNECTIONS.....	6-20
6.2.1 <i>Possibilities of Power Supply connection</i>	6-20
6.2.2 <i>Possible connection to frame</i>	6-22
6.2.3 <i>Possibilities of Volts and Current Shunt Sensors Connection</i>	6-23
6.2.4 <i>Transceiver connection</i>	6-25
7 INTEGRA DATA SHARING	7-1
7.1 EXPLANATION OF POSSIBLE CONNECTIONS.....	7-2
7.2 BACK UP SYSTEM RECOMMENDATION.....	7-2

7.3 INTEGRA CONNECTOR LOCATION..... 7-3

8 SENSOR CONNECTION..... 8-1

9 TL ELEKTRONIC EQUIPMENT CONNECTION..... 9-1

9.1 REMOTE COMPASS..... 9-1

9.2 SERVO..... 9-1

9.3 VIDEO CAMERA..... 9-2

10 OTHER EQUIPMENT CONNECTION..... 10-1

10.1 CO GUARDIAN..... 10-1

10.2 GARMIN SL – 30 10-2

10.3 TRANSPONDER..... 10-3

10.4 GPS 10-3

10.5 OTHER COMPATIBLE EQUIPMENT 10-4

11 CONCLUSION 11-1

1 Revision Table

Rev	Revision Date	Description	ECO#	Insertion date	By
PrA	15.04.2013	Initial version			Hovorka

2 General description

2.1 General Information

The INTEGRA stores general information. The pilot and/or owner of the aircraft is responsible for verifying that this information is accurate and complete. The pilot and/or owner is further responsible, on a regular basis, for maintaining this information and insuring that it is up to date and accurate. If the pilot and/or owner of the aircraft is unable or unwilling to do this the, files must be deleted.





When the installation is finished, inspect the system for loose fittings, connections, clamps, probes and inspect for leaks, chafing, obstructions, heat damage and anything that may cause unsafe flight before the 1st run-up, after the 1st run-up and after the first flight. The INTEGRA allows the pilot to enter checklists, and general information through the USB port. This data must be verified for its accuracy (by the pilot) before it is used.

Before allowing the aircraft to be flown, verify the instrument markings displayed on the INTEGRA screens are accurate with the aircraft's POH (Pilot's Operating Handbook) for every function displayed on the INTEGRA. Before allowing anyone to operate the aircraft read the User Manual including Notices therein. Keep the User Manual in the aircraft at all times.

2.2 Limited Warranty

This manual contains important information that may affect the safety of the pilot, passengers, aircraft, the operation of the system or time to install the system. You **MUST** read the manual prior to installing this system. Any deviation from these installation instructions is the sole responsibility of the installer and should be done in accordance with AC 43.13. Read the Warranty/Agreement. There is information in the Warranty/Agreement that may alter your decision to install this product. If you do not accept the terms of the Warranty/Agreement, do not install this product. This product may be returned for a refund. Contact TL elektronik Inc. for details.

⚡ WARNING: If the installer does not have the skills, knowledge, tools, equipment or facility, to perform and determine whether the installation of this product is safe, reliable and accurate and to determine whether this product is operating properly after installation, **DO NOT INSTALL THIS PRODUCT**. If the owner/pilot and/ or installer are unwilling to take the responsibility for the installation and operation of this product, **DO NOT INSTALL THIS PRODUCT**. This product may be returned for a refund. Contact TL elektronik Inc. for details.

-  **NOTE:** By installing this product, the aircraft owner/pilot and installer agree to hold TL-elektronic Inc. in no way responsible for monetary compensation, including punitive damages for any incident, harm and/or damage associated with this product. If you do not agree to the above, DO NOT INSTALL THIS PRODUCT. This product may be returned for a refund. Contact TL elektronik Inc. for details.
-  **NOTE:** TL-elektronic Inc. is not liable or responsible for a pilot's action or any situation that results in personal injury, property damage, missed commitments, lack of use of an aircraft or any expenses incurred due to: product failure, inaccuracy in displayed data or text files, display or display format issues, software bugs or problems, upgrade or customization issues, misinterpretation of the display, warning and/or limit settings, calibration problems, installation issues (leaks, incorrect wiring, obstructions, damage to aircraft or components, incorrect installation of any parts, wrong parts, parts that don't fit, etc.) or any other issues related to the installation or operation of this product. All of the above are solely the pilot's and/or installer's responsibility. The pilot must understand the operation of this product before flying the aircraft. The pilot will not allow anyone to operate the aircraft that does not know the operation of this product. The pilot will keep the instrument Operating Instructions in the aircraft at all times.
-  **WARNING:** Do not install a non-certified INTEGRA in a certified aircraft.
-  **WARNING:** Before starting the installation make sure the unit will fit in the location you intend to install it without obstructing the operation of any controls.
-  **CAUTION:** The INTEGRA must be calibrated to the aircraft's fuel system and the INTEGRA's accuracy must be verified before flying the aircraft.

3 Technical Specifications

Physical characteristic

Width	240.8 mm	9.480"
Height	178 mm	7.008"
Depth	75.5 mm	2.972"
Panel rectangle hole	233.8x172 mm	9.205"x6.772"
Weight without battery	1400 g	3.09 lb
Weight with battery	1500 g	3.31 lb

General Specifications

Operating Temperature Range	- 20°C to +60°C
Humidity	95% non-condensing
Altitude Range	10000 meters max (32808 feet max)
Power Range	10.0 to 32.0 Volts
Max. Signalization	30 Volts, 1 Ampere
Power Consumption	1.15 Ampere @ 14VDC without ext. sensors 1.83 Ampere when battery is charging
Vibration	5 to 500 Hz
Show Rate (LCD Refresh)	15 fps depends on volume of information displayed

Long-term Memory and communication

Storing Rate	0.1 to 60 seconds user selectable
Memory Capacity	Scheck®method
Data Saved Endurance	30 years
Rolling Memory life-time	100 000 hours @ 1 second storing rate

Communication

RS-232c	up to 115 200 bps
USB 1.1	12 Mb/s
USB 2.0	480 Mb/s
CAN BUS	1 Mb/s

Display parameters

Resolution	800x480 pixels
Brightness	800 cd/m2

Memory Card

Type	INTEGRA support SD and SDHC memory card
------	---

Encoder

Type of encoder	Mode C
Strobe signal from the transponder	Positive pulse 10 to 32 Volts (if positive pulse is applied, the output encoding data is enable)

Altitude encoded

Range / Resolution

Altitude & Encoder	-500 m to 9750 m @ 1013.25 mbar / 1m (-1600 to 32000 feet)
--------------------	---

Airspeed

Range / Resolution

Air speed	0 to 350 km/h / 1 km/h (0 knots to 189 knots / 0.54 knots)
Absolute maximum speed	500 km/h (270 knots)

Audio Input/Output

Transceiver input line	0.2 to 2 Volts (typ. 0.5 V)@1kHz – input impedance 600 Ω
Voice warning output line	typ. 300 mV@1kHz – output impedance 600 Ω
Audio output line	typ. 300 mV@1kHz – output impedance 600 Ω

RPM and Engine Hours

Range / Resolution

RPM	0 to 9999 rpm / 1 or 10 rpm
Engine time	0 to 9999 hours / 1min to 99 hours and 1/10 hour from 100 hours ±2 seconds @ 1 hour
Flight time	1 to 9999 hours / 1min to 99 hours and 1/10 hour from 100 hours ±2 seconds @ 1 hour

Sensor parameters / Instrument Measured Range/Accuracy

Low RPM Voltage	~6 to ~50 VAC / 300 to 9999 rpm / ±1 rpm
High RPM Voltage	~25 to ~80 VAC / 300 to 9999 rpm / ±1 rpm
Positive RPM Only	+6 to +60 VDC / 300 to 9999 rpm / ±1 rpm (can be use VAC)

AUX RPM

Input parameter	Positive pulse 8 to 32 Volts
Type of Switch	Inductive sensor of PNP type

AUX IN

Input positive	10 - 32 Volts
Input GND	-
Output	20 mA max (internal resistor 470 Ω)

Position Sensor

Range	0 - 5 KΩ
-------	----------

Backlight control

Manual control	turn knob
Automatic control	sun sensor
External control	5/12/24 Volts (max. 32 Volts)

Volts/Amps

Voltage	0 to ±60 Volts / 0.1 Volt DC
Current	±100 Amps / 0.1 Amps (current shunt output 1mV @ 1 Amp) DC

Temperature Sensor

Oil, water/CHT, AUX Temperature	0 – 8000 Ω
	0.5 – 4.5 Volts

Oil Pressure Sender

Excitation for Oil Pressure	10 Volts
Input Volt/Current/Resistance	0 - 5 Volts
	0 – 1000 Ω

Manifold Pressure Sender

Excitation for Manifold Pressure	5 Volts
Input Volt/Resistance	0 - 5 Volts
	0 – 1000 Ω

Fuel Pressure Sender

Excitation for Fuel Pressure	10 Volts
Input Volt/Resistance	0 - 5 Volts
	0 – 1000 Ω

Fuel Level Probe 1 and 2

Excitation for Fuel Level	10 Volts
Input Volt/Resistance	0 - 5 Volts
	0 – 1000 Ω

Fuel Flow Sensor

Excitation for Fuel Flow Sensor	10 Volts
Flow per hour	0 to 400L/h @ 8450 K_factor / 0.1 liter/hour (0.26US-Gallon/hours)
Flow per dist.	0 to 400L/h @ 8450 K / 0.1 liter/100km (0.26US-Gallon/100 miles)
Fuel quantity	0 to 999 Liters / 0.1 liter/hour (0.26US-Gallon/hours)
Fuel pressure	0 to 5 bars (72.5PSI) / 0.01 bar (0.14PSI)
Engine Hours	0 to 9999.5 hours / ±2 seconds @ 1 hour

Thermocouple Probe

Thermocouple K	-35°C to +1200°C / ±5°C / 1°C
Thermocouple J	-35°C to +900°C / ±2°C / 1°C

4 Install Recommendation

4.1 Introduction

Careful planning and consideration are required to achieve the desired performance and reliability from the INTEGRA.

4.2 Rack Consideration

Plan a location that gives the pilot complete and comfortable access to the entire INTEGRA and so that it is plainly visible from the pilot's perspective. Check that there is adequate depth for the rack in the instrument panel. A place away from heating vents or other sources of heat generation is optimal.

4.3 Calibration and testing of static pressure measurement for altitude determination

⚡ WARNING: It is necessary to pressurized all three outlets (AOA, Static, Pitot) during process of calibration and testing of static pressure sensor for altitude determination.

4.4 Installation into Panel

⚡ WARNING: Connect the cables into the connector.

⚡ WARNING: If possible, always use insulated wires connect to connect the Intercom so that you prevent possible interference from other equipment, which could result in interference in the headphones.

The diagram below shows the outside dimensions of the INTEGRA. Note that the instrument and tray extend about 101.5 mm or 3.996" behind the panel. Use the dimensions found on the diagram to plan for the space required by the instrument. Take the following considerations into account when selecting a mounting location for the INTEGRA. Avoid placing the instrument near heater vents or any source of extremely hot or cold air. Air surrounding the INTEGRA during operation may be no warmer than 60°C.

Plan a panel location that allows convenient viewing of the instrument with no obstruction. When flying straight and level, the panel angle from vertical may not be greater than +/- 30 degrees. The unit must be aligned as close as possible with the longitudinal and lateral axes of the aircraft. The firmware supports an adjustment for panel tilt, but not for mounting errors in yaw or roll. Correct attitude performance depends on mounting the INTEGRA square with the direction of flight. To mount the INTEGRA, you must make a rectangular cut out in your panel. Ensure that the dimensions of the cut out are: 9.205" = 233.8 mm wide and 6.772" = 172 mm tall. Place the INTEGRA-series mounting tray behind the cut out. Secure it to your panel by Riveting or Screws. Riveting is recommended, but drilling holes for mounting screws and nuts will work as well.

 **WARNING:** Avoid applying paint to the mounting rack. The thickness of a coat of paint may distort the rack dimensions.

 **NOTE:** When mounting, the INTEGRA frame will not be flush with rack mounting screws. The screws will be exposed after mounting the INTEGRA. Before painting it is necessary to apply putty around the screws.

Upon securing the mounting rack to the back of your panel, slide the INTEGRA into it.

4.5 Recommended Wiring Practices

For all electrical connections, use correct wiring techniques, taking care to properly insulate any exposed wire or cables. A short circuit between any of the wires may cause damage to the INTEGRA and/or your aircraft. Make all connections to your harness before connecting it into any of the components of the system. Do not make connections while INTEGRA is turned on or power is applied at any point in the system. We recommend that all wire you use also meets 22 AWG Mil Standard MIL-W-22759/16; – with the exception of the thermocouple harnesses. When using any pre-manufactured harness, verify that each pin has continuity with the expected wire on the wiring diagram. This test can be easily done with a multimeter. When verifying harnesses. Use the wiring charts and diagrams in this guide. Use appropriate strain relief at all junctions between wires and connectors. We recommend that you secure all wires at regular intervals along wiring runs to accommodate vibration effects.

4.6 Thermocouple Harness Preparation

Refer to Thermocouple connection on page 6-19 during this procedure.

Strip ¼” of insulation from each of the thermocouple wires inside. Crimp the supplied male Fastons onto each wire on the thermocouple harness. These will later be inserted into the female Fastons on each thermocouple. Do not connect the Fastons on the harness with those on the thermocouples until you have routed the wires and mounted the thermocouples at the desired location. The thermocouple wires can be cut to a desired length if your application requires. If you need to extend the length of the thermocouple, you must use the correct type (J or K) thermocouple wire to accomplish this. It is acceptable to use non-thermocouple fasteners to join two pieces of thermocouple pair wire, provided the junction does not extend very far or have large temperature differences across it. Please contact TL electronic to order extension wire.

4.7 Harness Mating

The following diagram shows the connectors on the back of the INTEGRA. From the right side the first two connectors are used for the EFIS portion (also used to provide power to the instrument) of the product; the two connectors on the left are used for the EMS portion. The main EMS harness (for all connections except EGT & CHT thermocouples) must terminate in a 37-pin male D-sub connector. The EGT/CHT thermocouple harness must terminate in a 25-pin female D-sub connector. The following pages provide wiring diagrams and details for each of these harnesses.

4.8 Power Requirements

22 AWG wire is normally sufficient for the power supply and grounding, but we recommend that you consult a wire sizing chart and determine the size required for the wire routing in your particular aircraft. Ensure that the power supply include a circuit breaker

4.9 Wiring Overview

The INTEGRA power requirement is as low as 3 amps in a 12/24 volt system. And therefore you can use a 3-amp circuit breaker. See the technical specification chart for details.

4.10 Grounding

Many of the engine sensors require a connection to a aircraft ground with the INTEGRA. There are many places on an aircraft where you could connect these sensors. However, the ideal location to ground these sensors is near the INTEGRA to minimize voltage differences between the sensor and instrument grounds. Some sensors (e.g., oil pressure and oil temperature) connect to ground via their cases' contact with the engine or aircraft body. There must be a solid connection between this "case ground" and the INTEGRA ground. The oil temperature sensor is very susceptible to voltage differences between the engine case and the negative terminal of the battery. Ensure that solid, thick electrical connections exist between the engine and battery ground. Some sensors do not have a grounded case and have two leads instead. This sensor with tow out puts will not be affected by the differences described above.

In the case of one output sensors (second output is the body of sensors) measuring can be affected by current drawn between the instrument ground and the battery ground that can cause voltage differences which adversely affect engine sensor readings.

5 Mechanical Drawing

NOTE: Main unit for dimensions in the mechanical drawings is millimeters; values in square brackets are in inches.

5.1 Front View

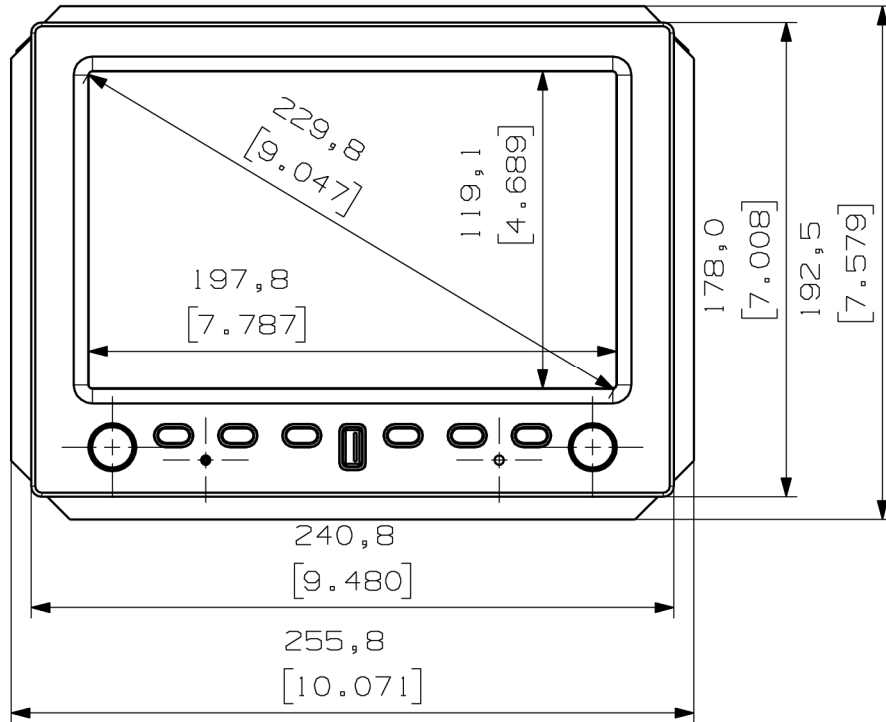

5.2 Side View

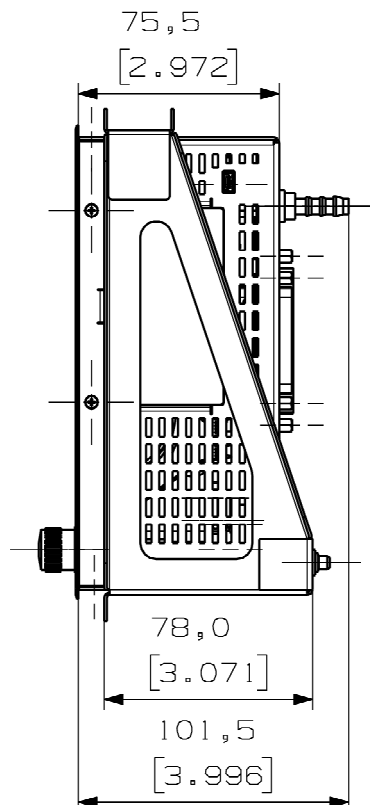

5.3 Rear View

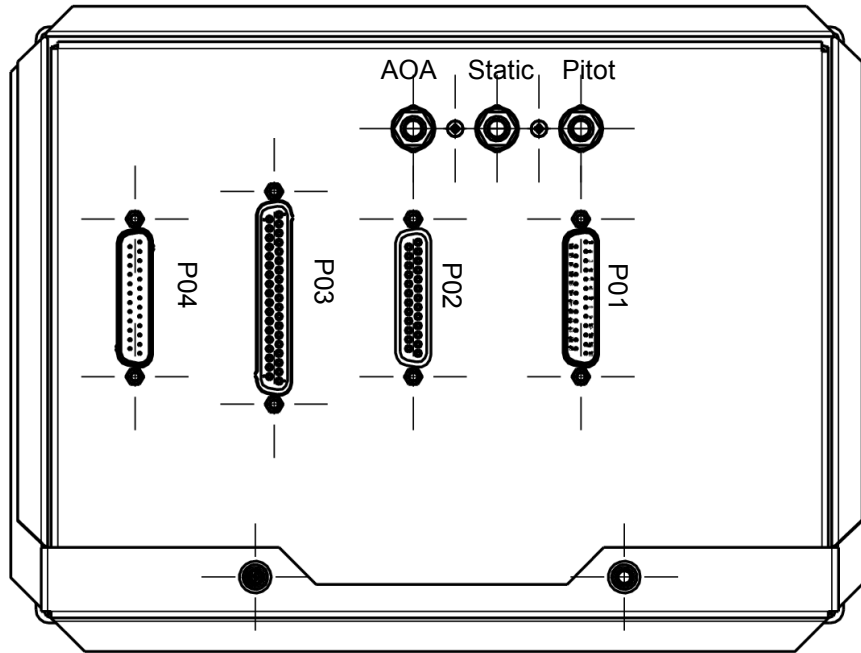

5.4 Front View of Mounting Rack

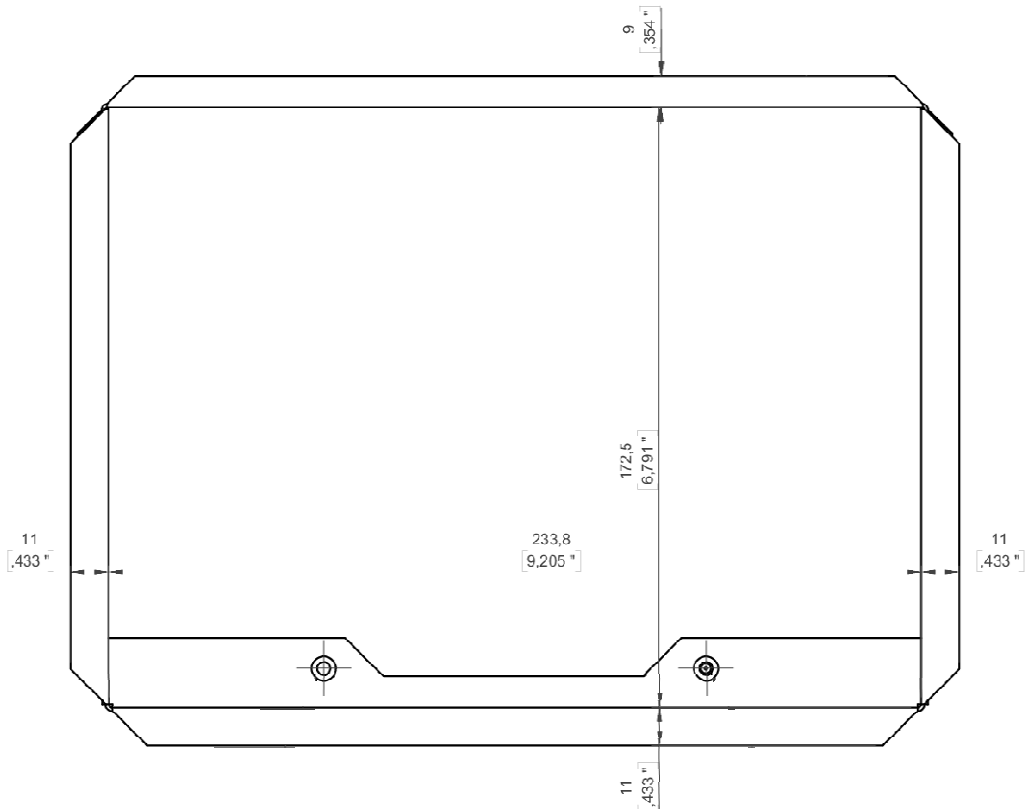

5.5 Side View of the Mounting Rack

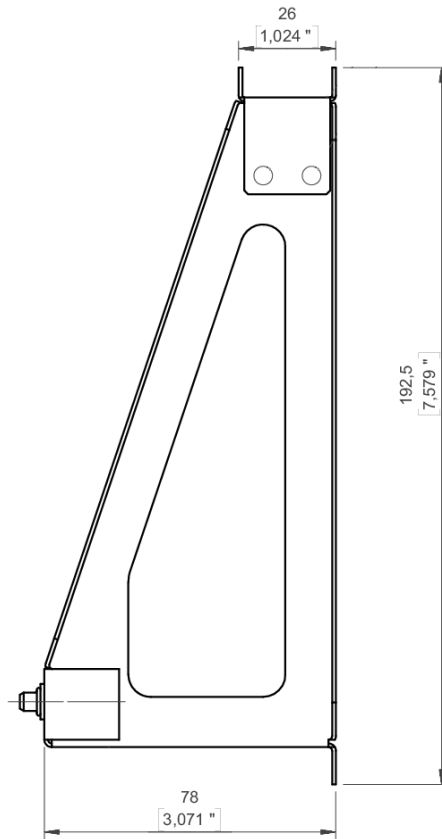

5.6 Panel Cutout

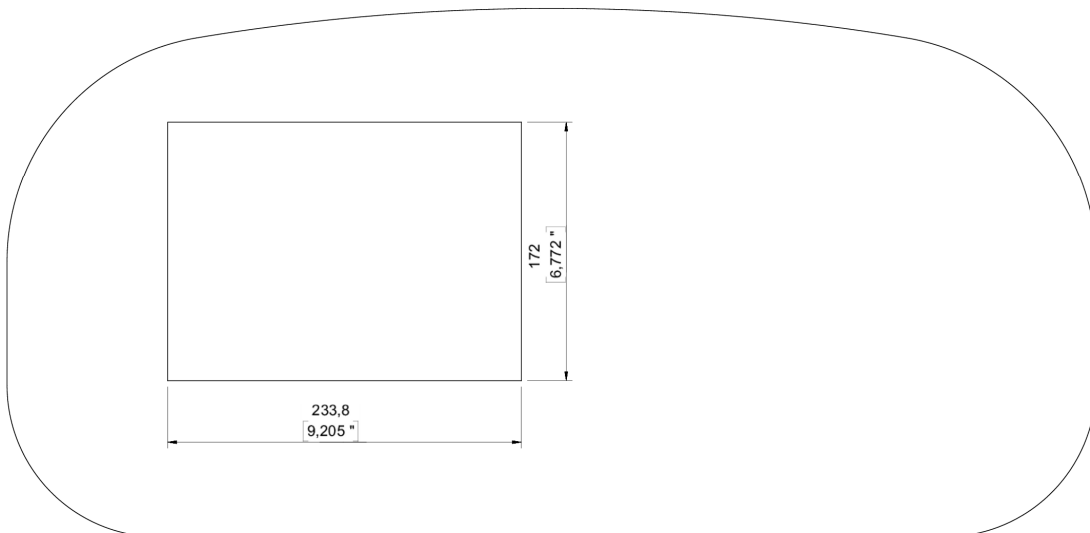

NOTE: For more information about installation into the panel look at chapter 4.4

5.7 INTEGRA Mounting Diagram

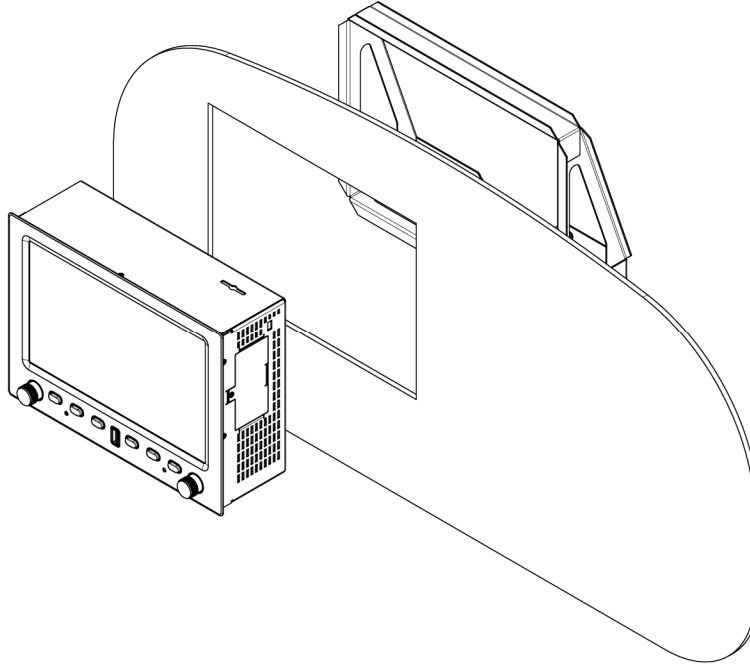

i **NOTE:** For more information about installation into the panel look at chapter 4.4

6 Electrical Drawing

6.1 PIN FUNCTION list

Main Connector P01– type: D-SUB25 – Male (connector on INTEGRA)

Pin	Pin Name	I/O
1	Aircraft Power (10 to 32V)	In
2	Main switch (10 to 32 V)	In
3	N/A	--
4	iFamily® Bus1 (CANH)	I/O
5	Audio out - Left (HI - pilot headphones or IC)	Out
6	Audio out - Right (HI - pilot headphones or IC)	Out
7	Transceiver Phone	--
8	Altitude output – A1	Out
9	Altitude output – A2	Out
10	Altitude output – A4	Out
11	Altitude output – B1	Out
12	Altitude output – B2	Out
13	External Signalization	In
14	Aircraft GND	--
15	External Back-Up battery (10 to 32 V)	In
16	N/A	--
17	iFamily® Bus1 (CANL)	I/O
18	Ground for audio out	Out
19	Ground for transceiver phone	I/O
20	Altitude output – B4	Out
21	Altitude output – C1	Out
22	Altitude output – C2	Out
23	Altitude output – C4	Out
24	*Strobe signal	In
25	Ground	--

*Strobe signal is function of the transponder, which use strobe signals to enable and disable the encoder.

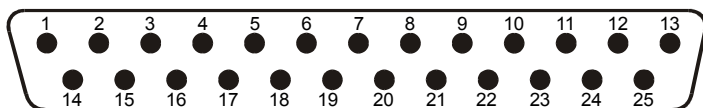

notation of pins D-SUB 25 Male connector

6.1.1 Power, Signalization, Transceiver and iFamily® Interconnect

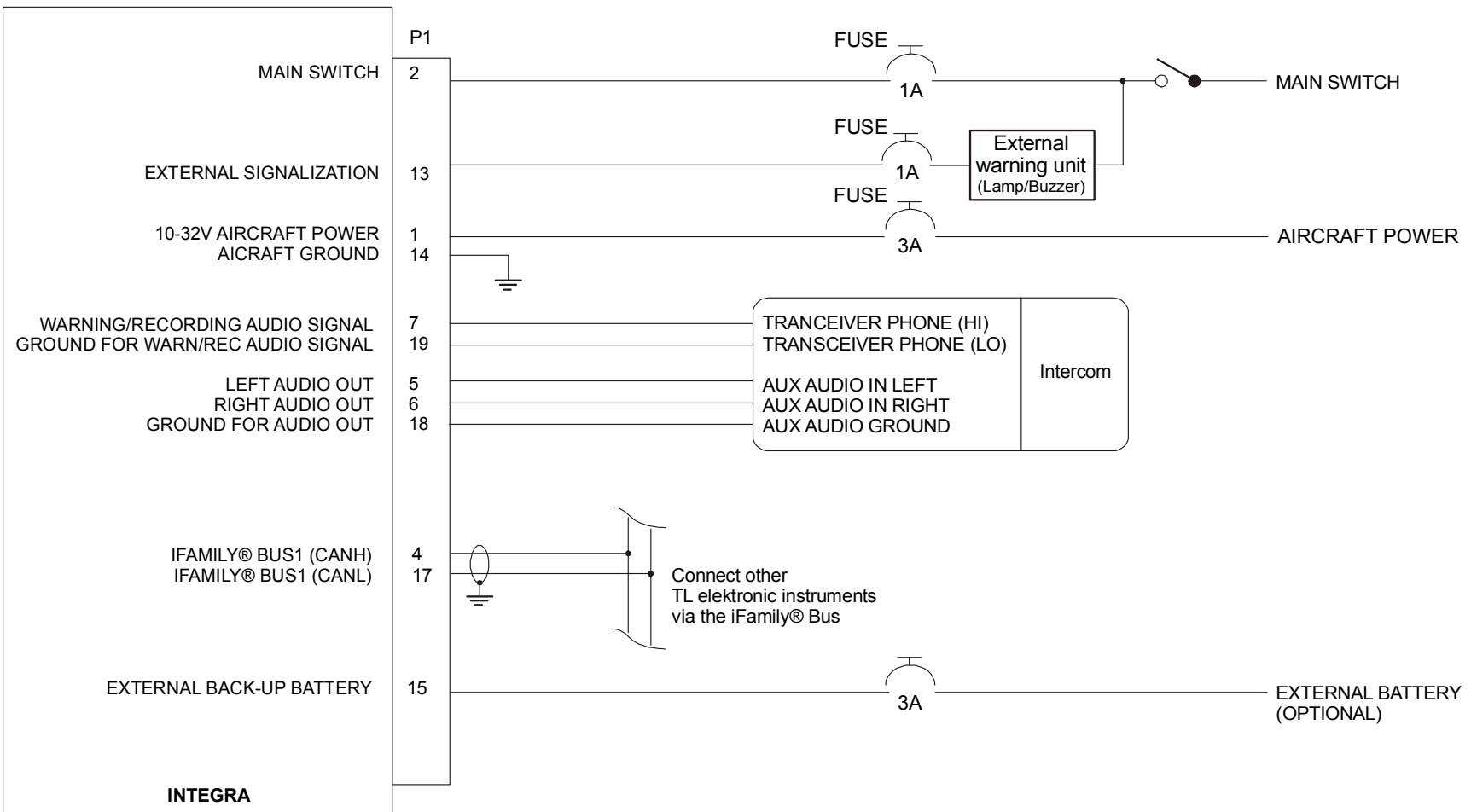

6.1.2 Transponder Interconnect

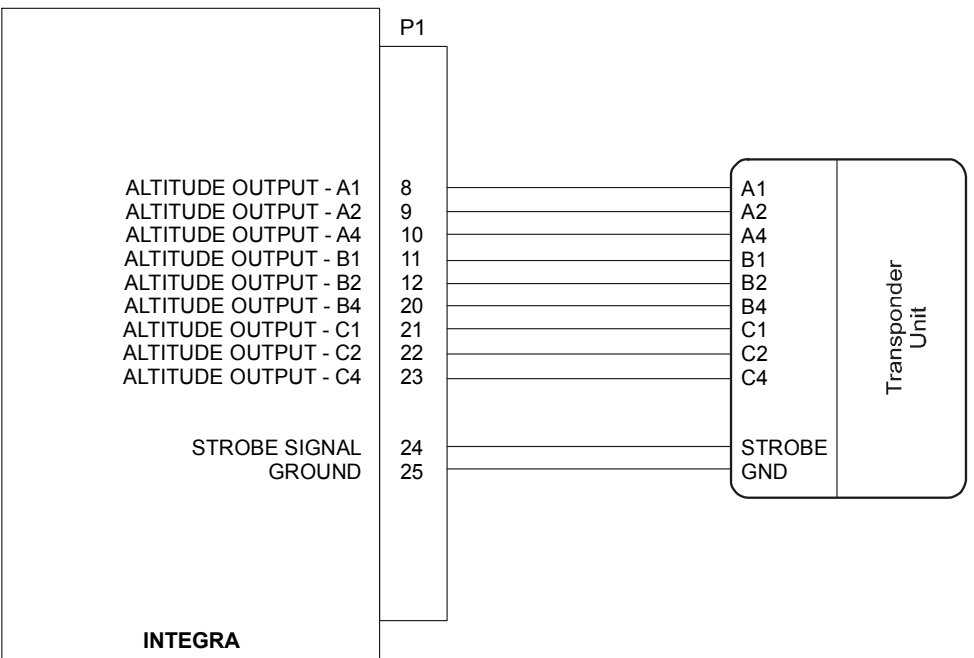

Inputs and Communication Connector P02 – type: D-SUB25 – Female (connector on INTEGRA)

Pin	Pin Name	I/O
1	iFamily® Bus2 (CANH)	I/O
2	N/A	--
3	COM1 RS-232 (RX)	In
4	COM1 RS-232 (TX)	Out
5	COM2 RS-232 (GND)	--
6	RPM - Positive pulse only	In
7	RPM - High amplitude	In
8	Auxiliary No.1	I/O
9	Auxiliary No.2	I/O
10	Auxiliary No.3	I/O
11	Position input	In
12	Inside air temperature sensor	In
13	Outside air temperature sensor	In
14	iFamily® Bus2 (CANL)	I/O
15	N/A	--
16	COM1 RS-232 (GND)	--
17	COM2 RS-232 (RX)	In
18	COM2 RS-232 (TX)	Out
19	RPM - Low amplitude	In
20	RPM - Ground for sensor	--
21	Auxiliary No.4	I/O
22	Auxiliary No.5	In
23	Ground for position input	--
24	Ground for inside air temperature sensor	--
25	Ground for outside air temperature sensor	--

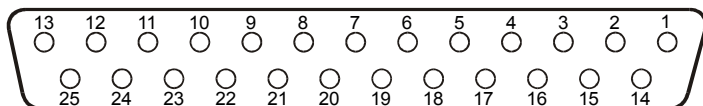

notation of pins D-SUB 25 Female connector

6.1.3 Auxiliary Ports and iFamily® Interconnect

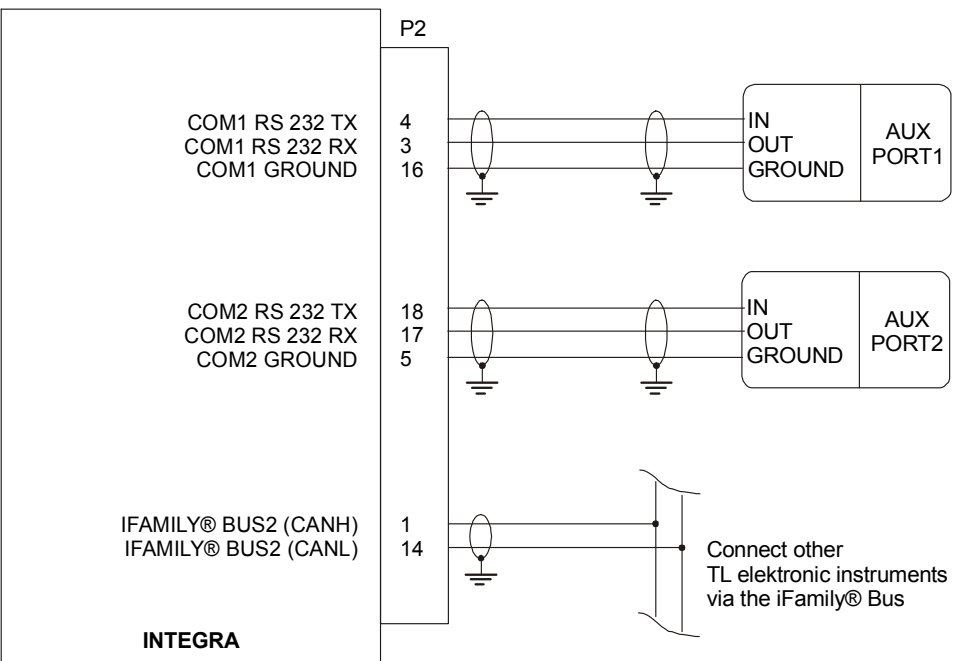

6.1.4 Auxiliary Input/Output Interconnect

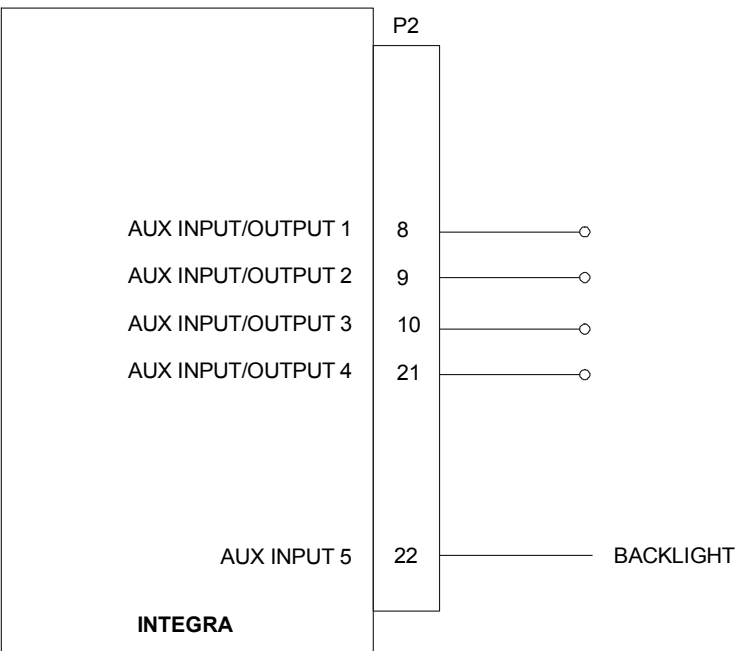
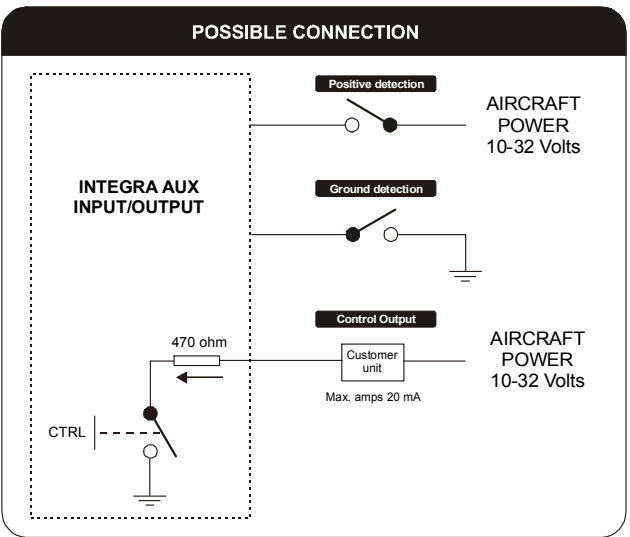

6.1.5 IAT and OAT Interconnect

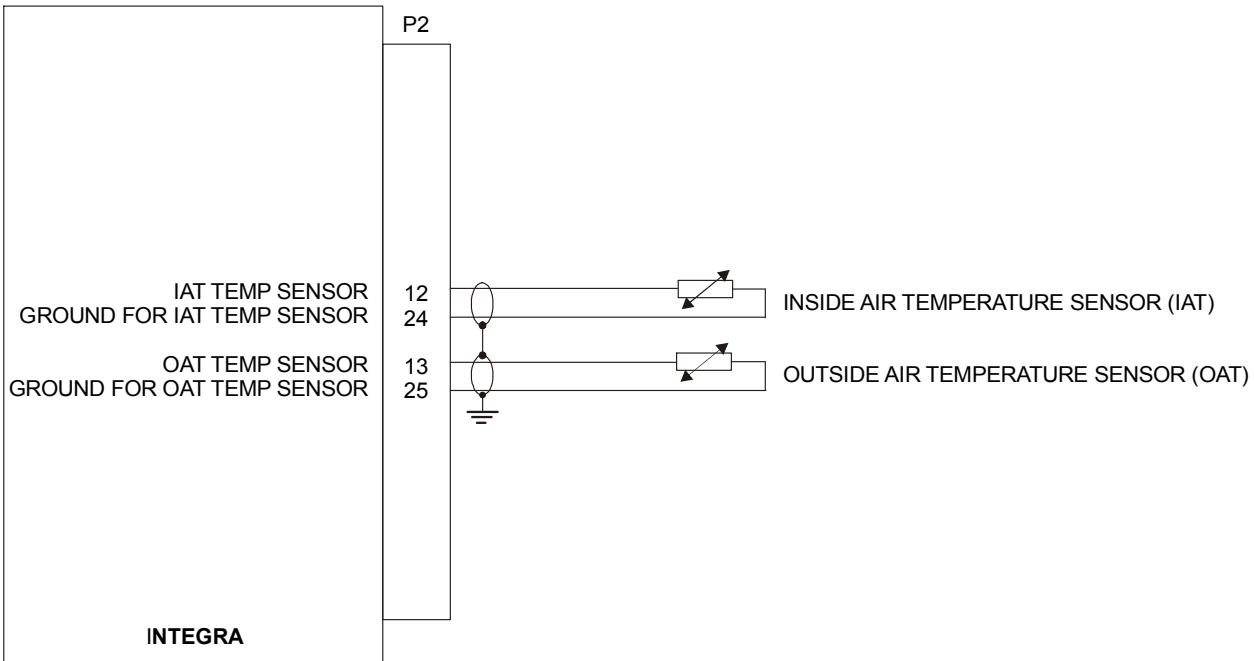

6.1.6 Position Interconnect

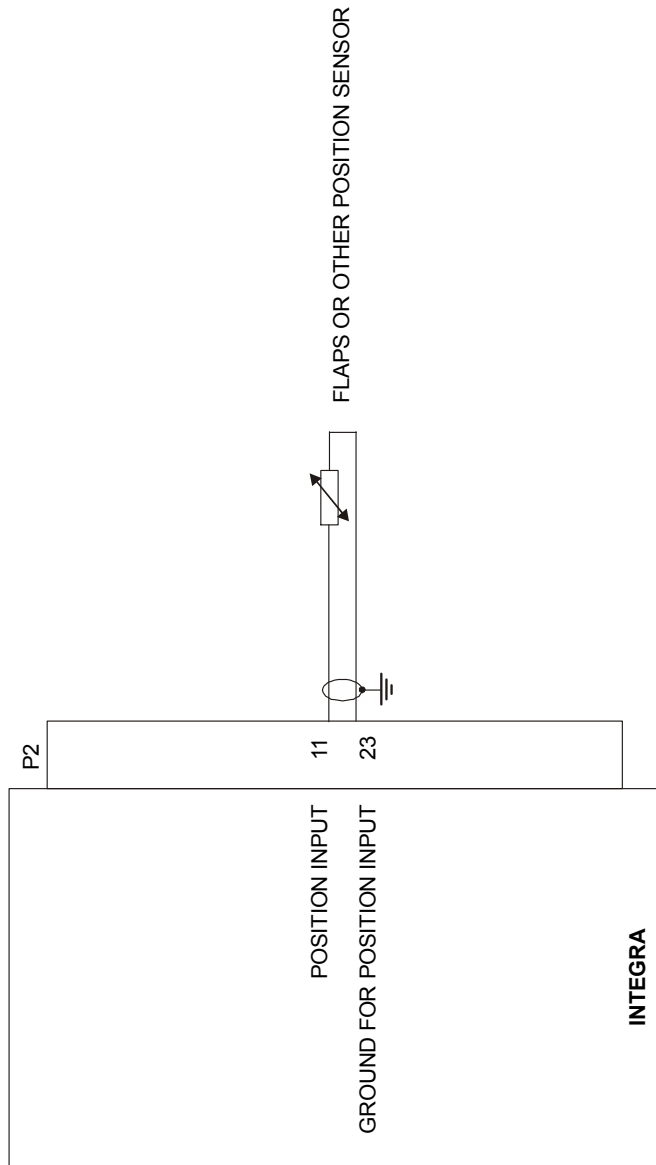

6.1.7 Engine RPM Interconnect

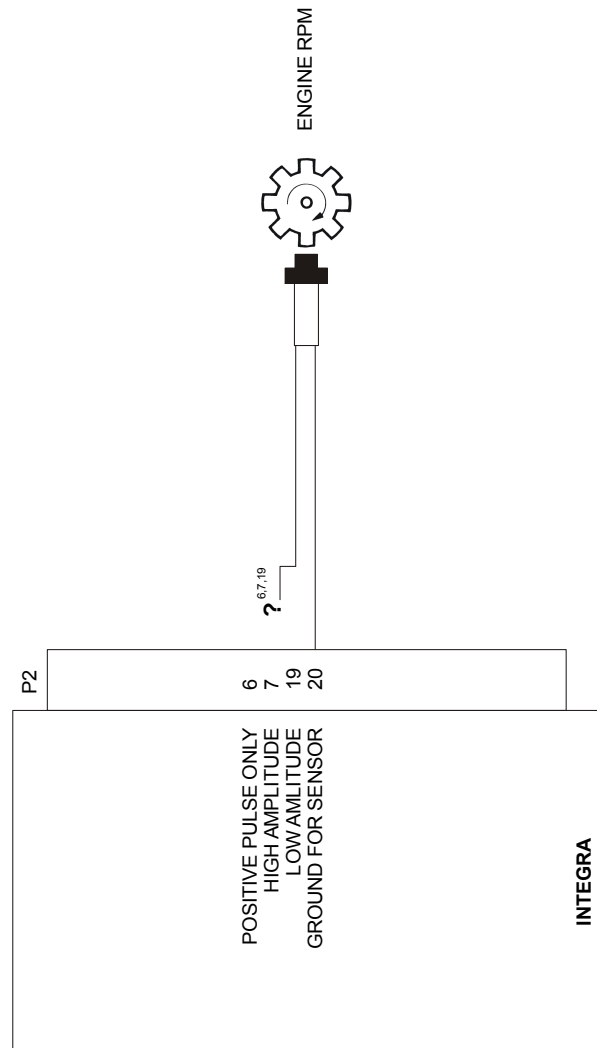

Sensors Connector P03 – type: D-SUB37 – Female (connector on INTEGRA)

Pin	Pin Name	I/O
1	Auxiliary RPM pulse	In
2	Power for auxiliary RPM sensor	Out
3	Oil temperature	In
4	Water/CHT temperature	In
5	Auxiliary temperature	In
6	Oil pressure	In
7	Power for oil pressure	Out
8	Ground for fuel pressure sensor	--
9	Manifold pressure	In
10	Power for manifold pressure	Out
11	Ground for fuel level sensor 1 (LEFT or TOTAL TANK)	--
12	Fuel level sensor 2 (RIGHT TANK)	In
13	Power for fuel level sensor 2 (RIGHT TANK)	Out
14	Ground for fuel flow sensor	--
15	Voltage No.1	In
16	Voltage No.2	In
17	Current No.1 (HI)	In
18	Current No.2 (HI)	In
19	Current No.3 (HI)	In
20	Ground for auxiliary RPM sensor	--
21	Ground for oil temperature	--
22	Ground for water/CHT temperature	--
23	Ground for auxiliary temperature	--
24	Ground for oil press	--
25	Output from fuel pressure sensor	In
26	Power for fuel pressure	Out
27	Ground for manifold pressure	--
28	Fuel level sensor 1 (LEFT or TOTAL TANK)	In
29	Power for fuel level sensor 1 (LEFT or TOTAL TANK)	Out
30	Ground for fuel level sensor 2 (RIGHT TANK)	--
31	Output from fuel flow sensor	In
32	Power for fuel flow sensor	Out
33	Ground for voltage	--
34	Voltage No.3	In
35	Current No.1 (LO)	In
36	Current No.2 (LO)	In
37	Current No.3 (LO)	In

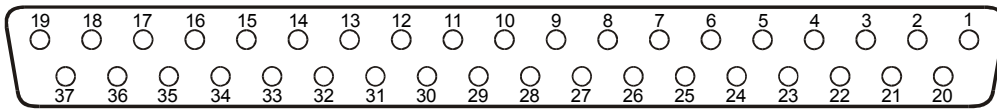

notation of pins D-SUB 37 Female connector

6.1.8 RPM and Temperature Sensor Interconnect

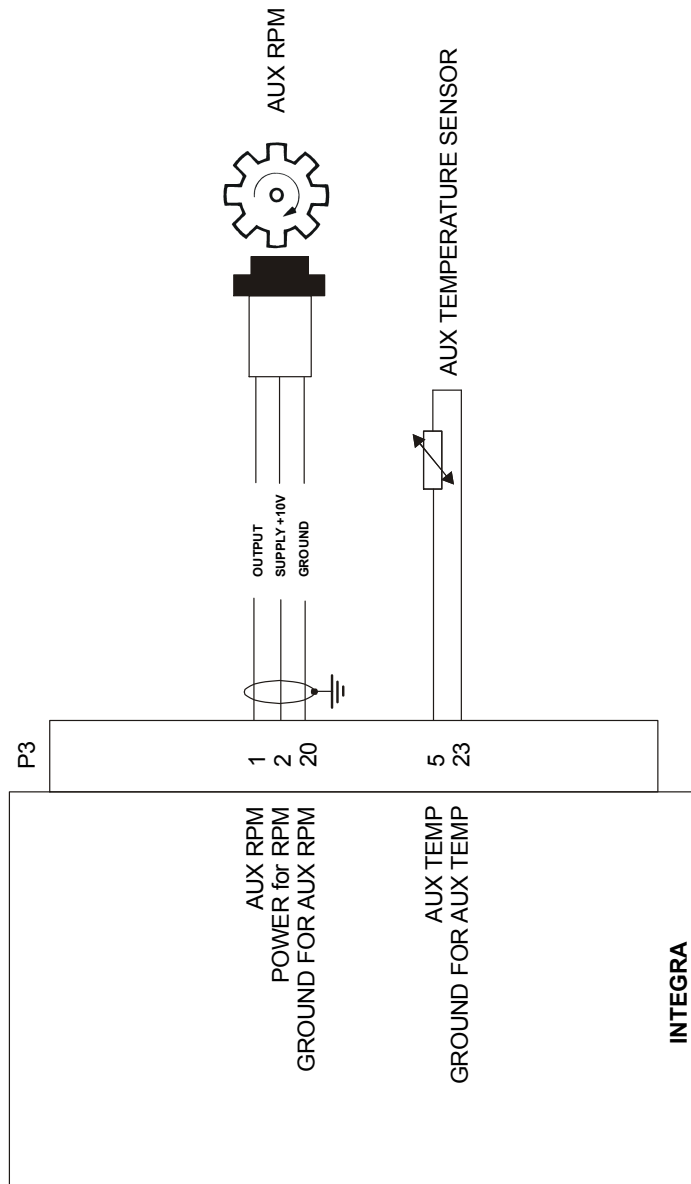

6.1.9 Volts and Shunt Sensor Interconnect

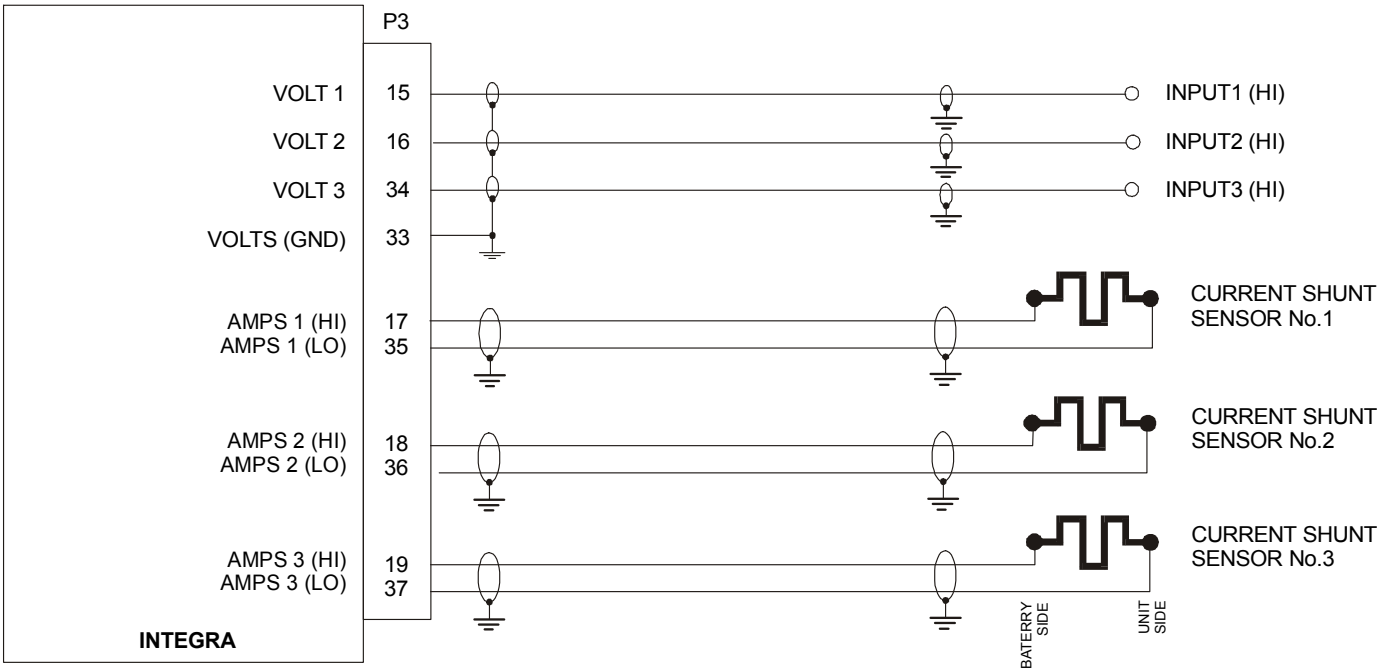

6.1.10 Fuel Sensors Interconnect - (Passive)

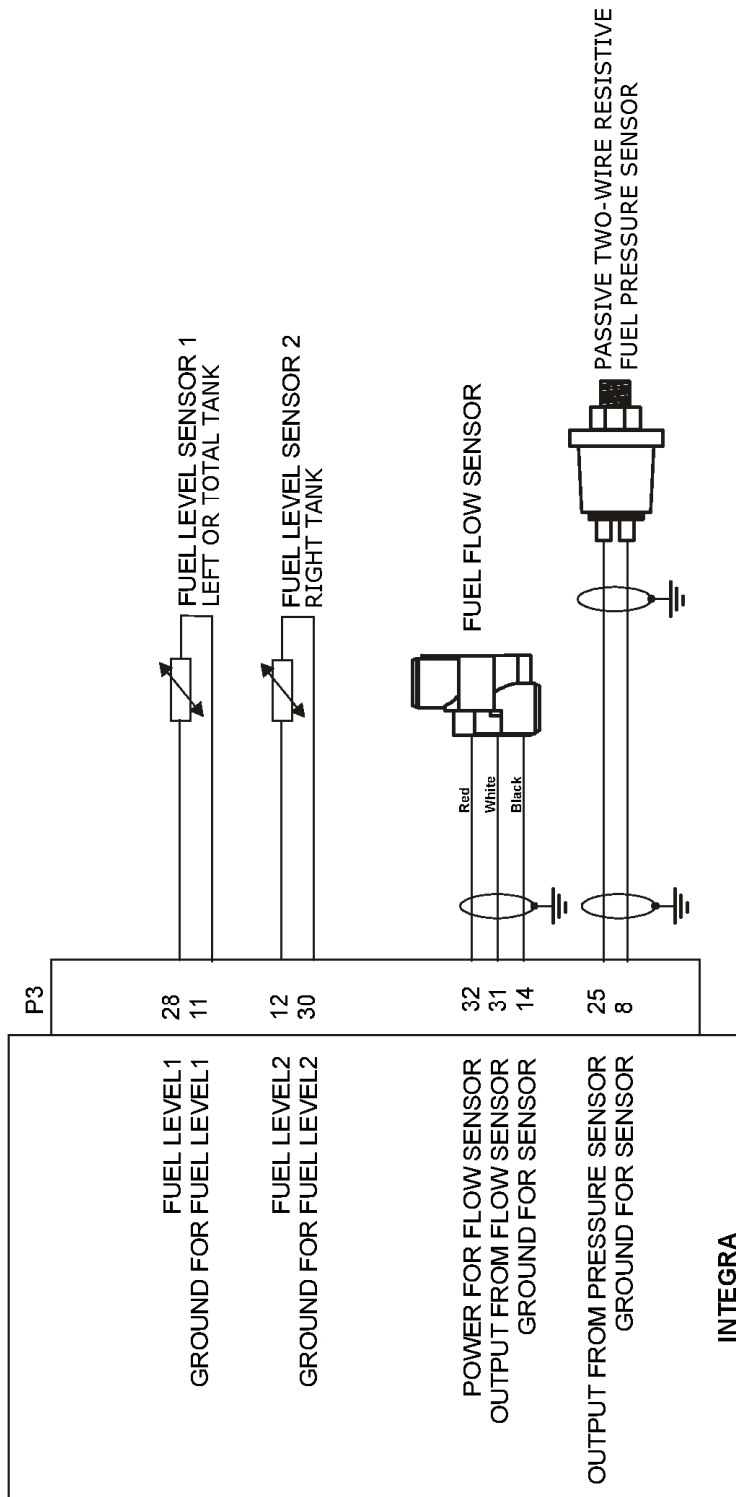

6.1.11 Fuel Sensors Interconnect - (Active)

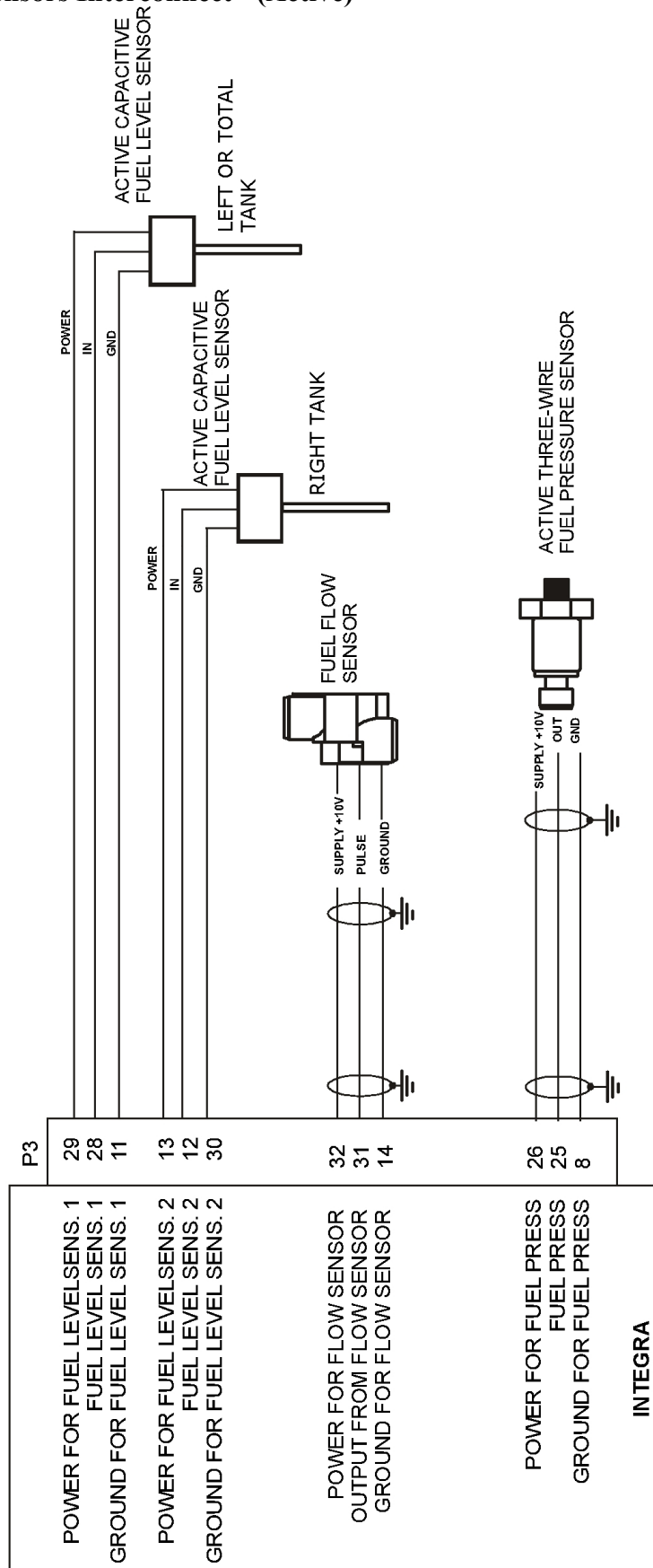

6.1.12 Oil, Water/CHT Temperature and Oil Pressure - (Passive)

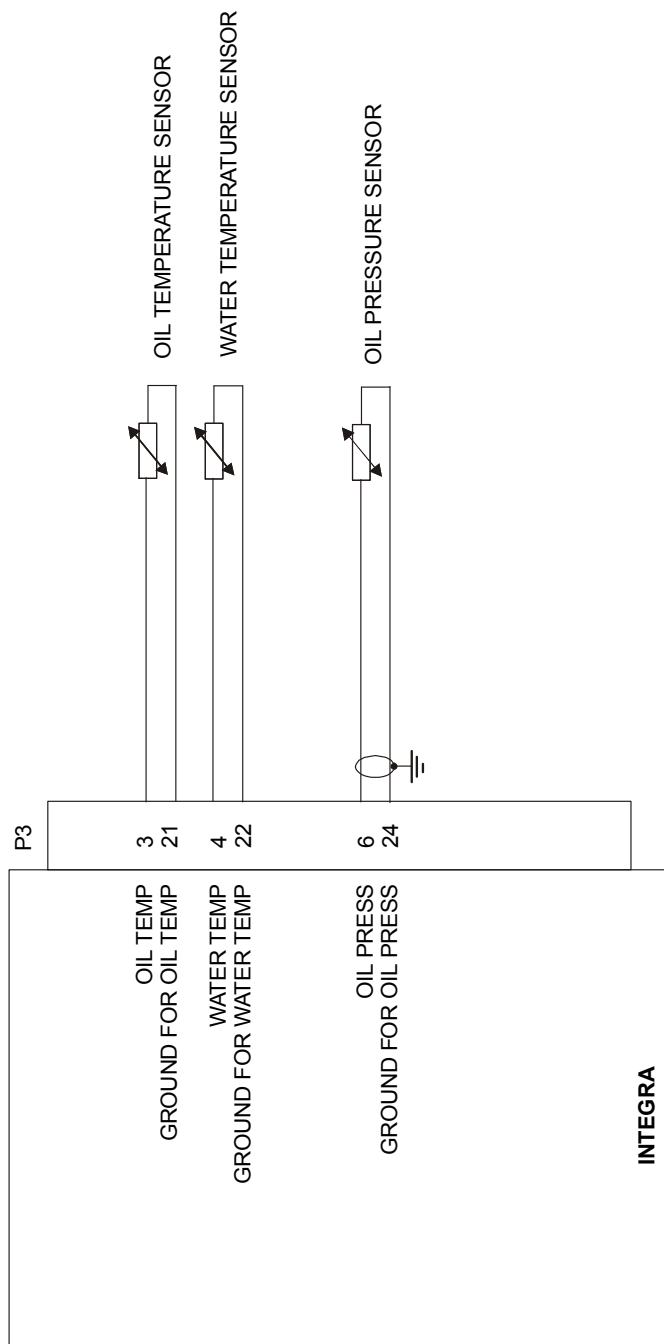

6.1.13 Oil, Water/CHT Temperature and Oil, Manifold Pressure - (Active)

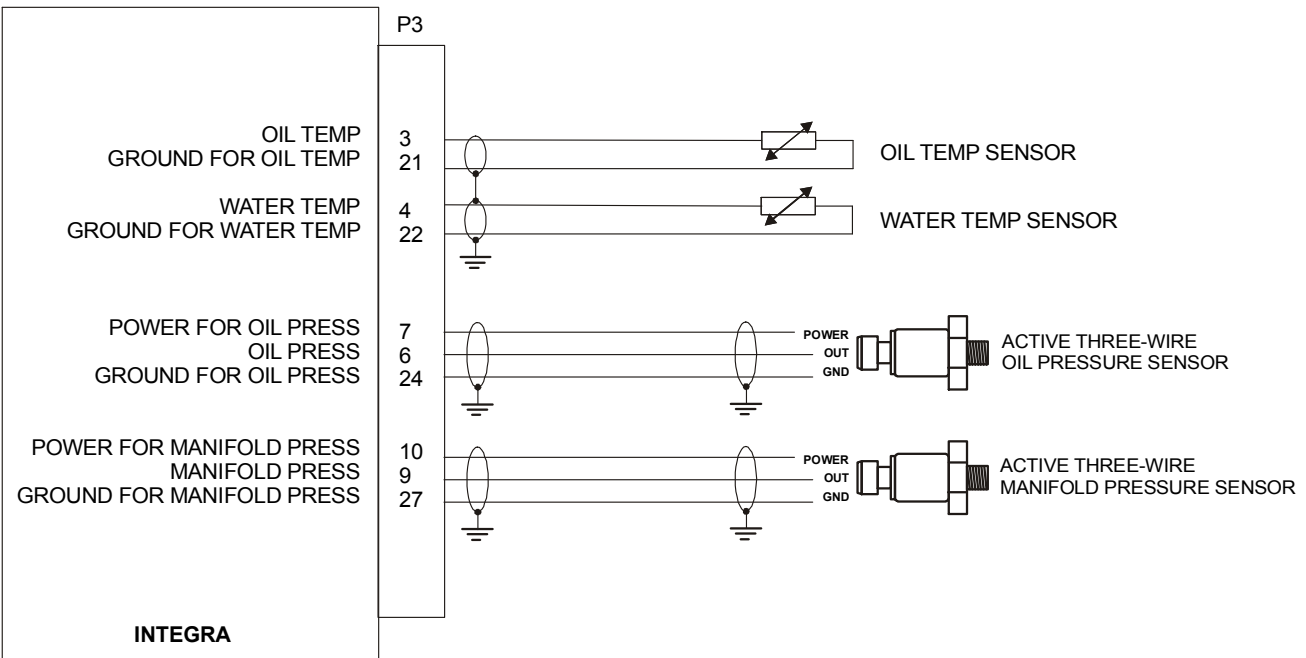

6.1.14 Oil and Fuel Pressure - (Current Loop)

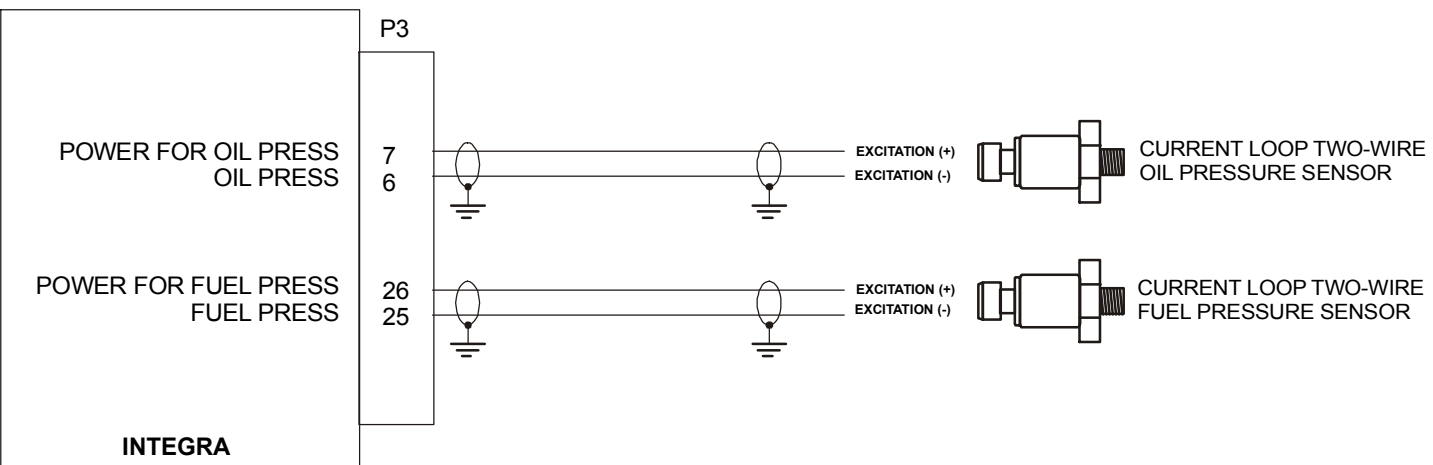

Thermocouple Connector P04 – type: D-SUB25 – Male (connector on INTEGRA)

Pin	Pin Name	I/O
1	Not Connected	- -
2	Thermocouple No. 1 (+)	In
3	Thermocouple No. 2 (+)	In
4	Thermocouple No. 3 (+)	In
5	Thermocouple No. 4 (+)	In
6	Thermocouple No. 5 (+)	In
7	Thermocouple No. 6 (+)	In
8	Thermocouple No. 7 (+)	In
9	Thermocouple No. 8 (+)	In
10	Thermocouple No. 9 (+)	In
11	Thermocouple No. 10 (+)	In
12	Thermocouple No. 11 (+)	In
13	Thermocouple No. 12 (+)	In
14	Thermocouple No. 1 (-)	In
15	Thermocouple No. 2 (-)	In
16	Thermocouple No. 3 (-)	In
17	Thermocouple No. 4 (-)	In
18	Thermocouple No. 5 (-)	In
19	Thermocouple No. 6 (-)	In
20	Thermocouple No. 7 (-)	In
21	Thermocouple No. 8 (-)	In
22	Thermocouple No. 9 (-)	In
23	Thermocouple No. 10 (-)	In
24	Thermocouple No. 11 (-)	In
25	Thermocouple No. 12 (-)	In

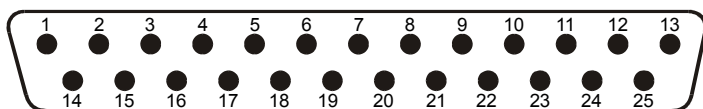

notation of pins D-SUB 25 Male connector

6.1.15 Thermocouples

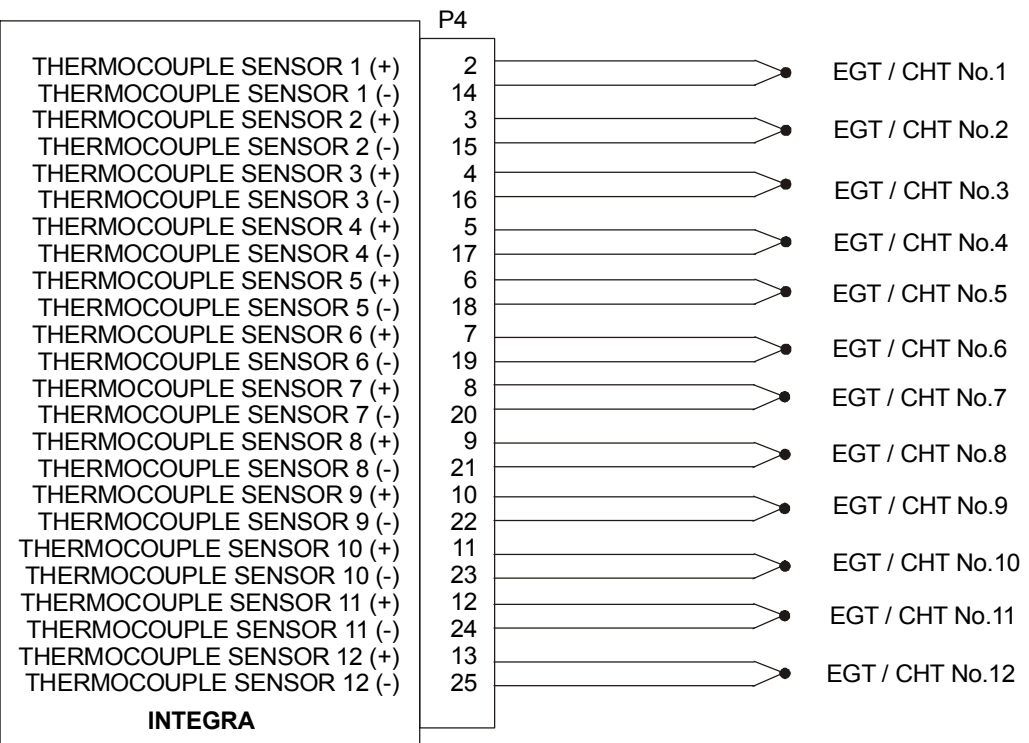

⚠ CAUTION: The thermocouple sensor is a very precise sensor based on the physical phenomenon of two different cables that are connected in the place of measuring. For this reason it is necessary to lengthen these sensors only with an extension cable that is suitable for the particular type of sensor.

6.2 Recommended connections

6.2.1 Possibilities of Power Supply connection

The following possibilities of power supply connection are applied in case the backup battery of Integra is not connected.

6.2.1.1 Mostly recommended option

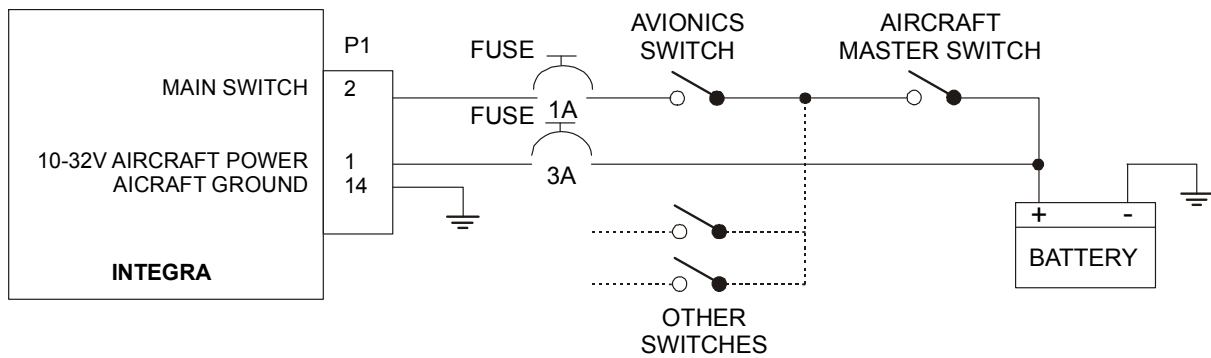

NOTE: Protection by fuse of pin no.2 is recommended as it is shown on picture. The reason is protection against accidental short circuit caused by connector manipulation or failure of cable insulation.

Advantage of this option:

The Integra Quick Start function is available for this option of power supply connection. With this function the Integra can perform quick switch on in 2 seconds after Aircraft Master Switch and Avionics Switch is ON.

Disadvantage of this option:

The Integra is permanently consumes power of 0.5 mA of aircraft battery due its standby state.

6.2.1.2 Recommended option

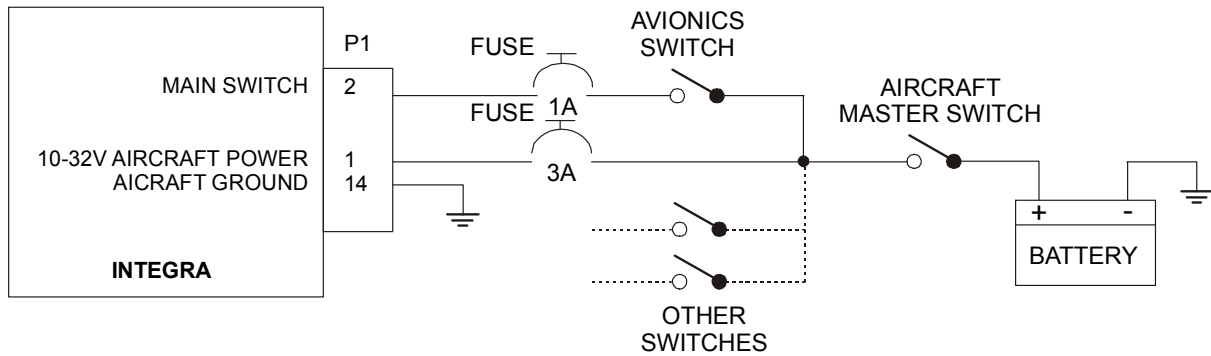

NOTE: Protection by fuse of pin no.2 is recommended as it is shown on picture. The reason is protection against accidental short circuit caused by connector manipulation or failure of cable insulation.

Advantage of this option:

When the Avionics Switch disconnects the pin no.2, the Integra will detect off-state and will be switched off by regular way in 5 seconds. Then the Integra power supply could be disconnected without any harm by Aircraft Master Switch.

Disadvantage of this option:

If the Integra power supply is disconnected by Aircraft Master Switch sooner than in 5 seconds, the latest records in memory could be damaged and therefore they could not be available for inspection. This does not apply to Crash Memory.

6.2.1.3 The least convenient option

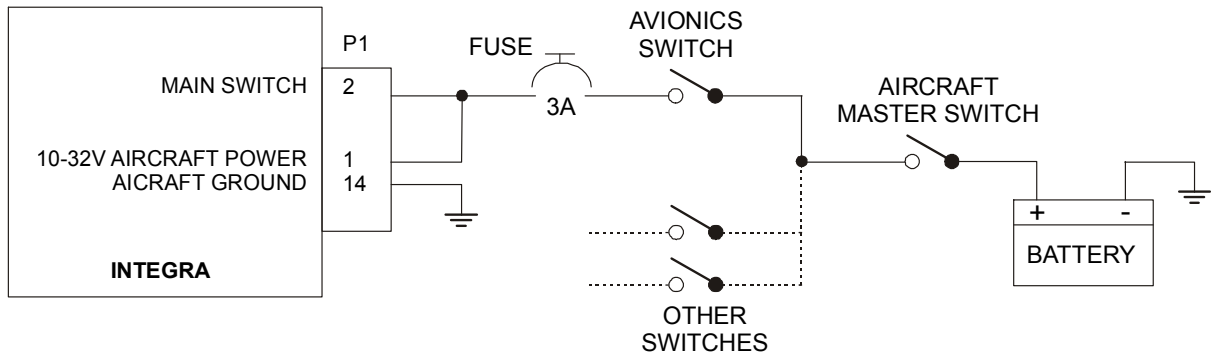

Advantage of this option:

It's simple.

Disadvantages of this option:

The switch (Avionics Switch or Aircraft Master Switch) disconnects the Integra from power supply.

This can result in error of data storage. In case of the error, the sequence of latest records in memory could be damaged and therefore it could not be available for inspection. This does not apply to Crash Memory.

6.2.2 Possible connection to frame

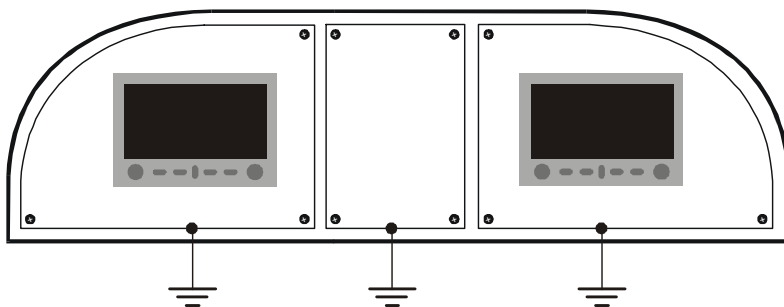

NOTE:

The connection to frame of dashboard is recommended, because the metal case of Integra is in contact with metal plate of dashboard. In case dashboard is not connected to frame and onboard systems are simultaneously connected to dashboard, current would flow through the case of Integra and it may result in damage of the Integra.

6.2.3 Possibilities of Volts and Current Shunt Sensors Connection

6.2.3.1 The typical connection in case of one current shunt sensor

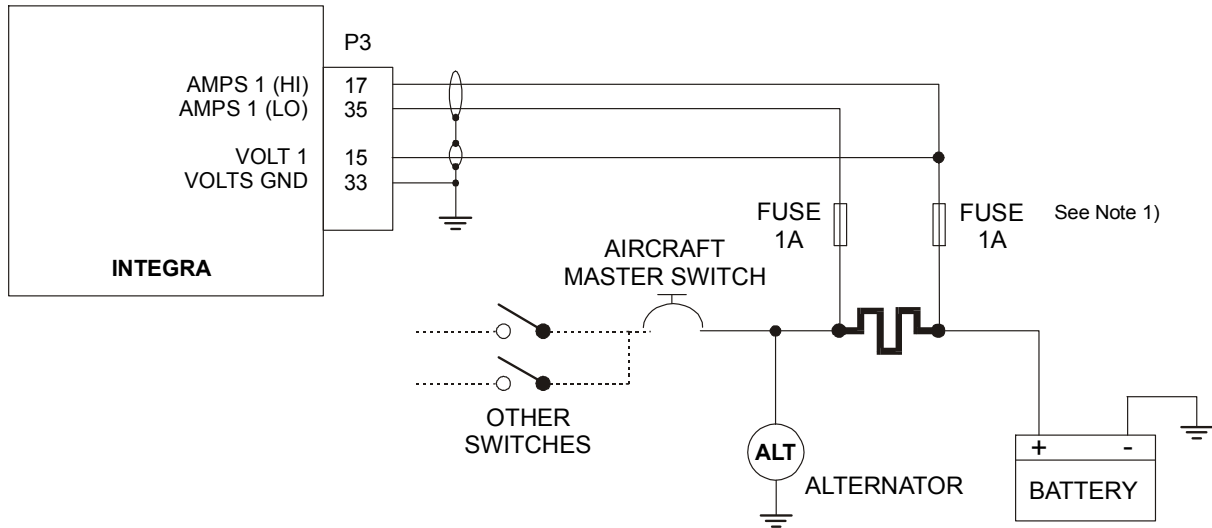

NOTE 1: Protection by fuse is recommended as it is shown on picture. The reason is protection against accidental short circuit caused by connector manipulation or failure of cable insulation.

6.2.3.2 Possible connection for full configuration

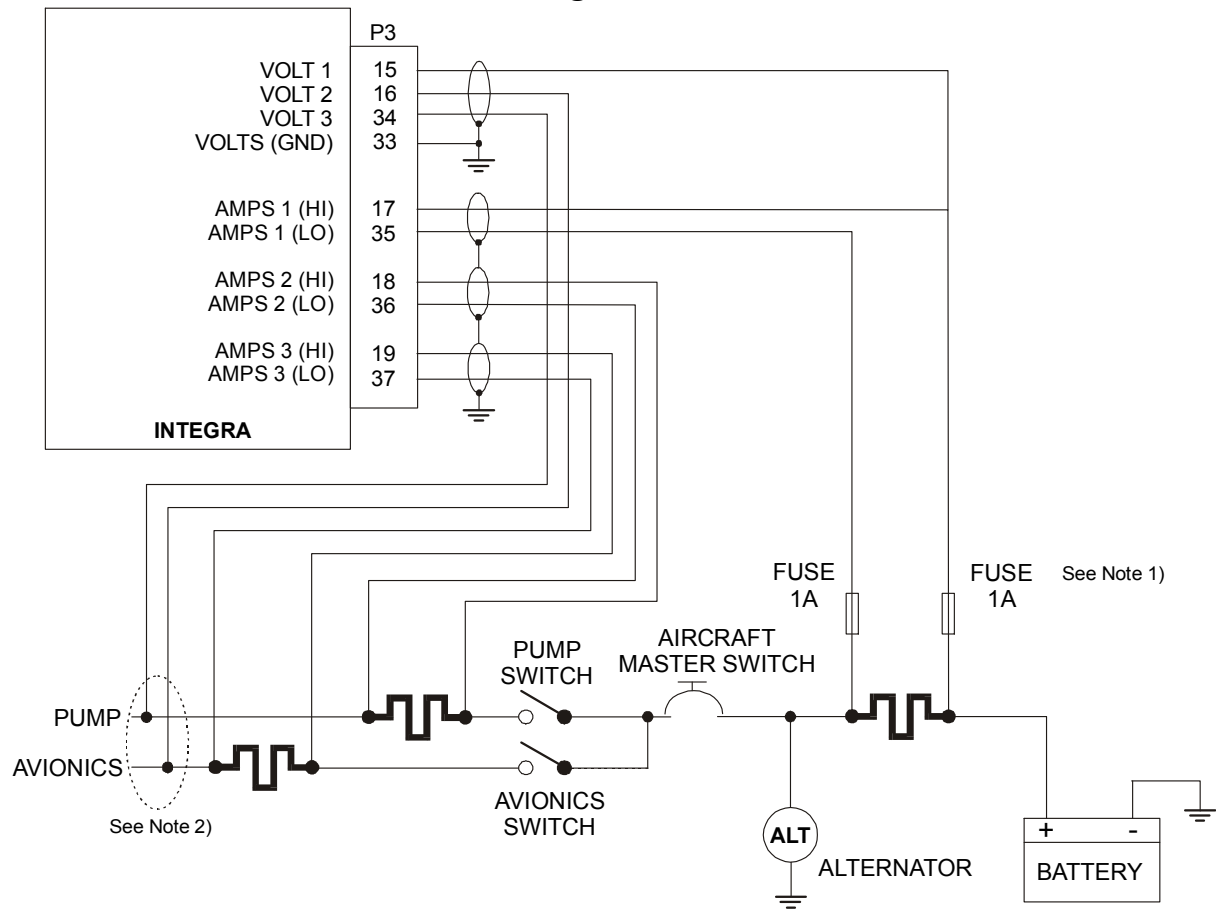

NOTE 1: Protection by fuse is recommended as it is shown on picture. The reason is protection against accidental short circuit caused by connector manipulation or failure of cable insulation.

NOTE 2: Cables for voltage measurement should be as short as possible. Because of cable voltage drop, this is cause of possible measurement imprecision.

6.2.4 Transceiver connection

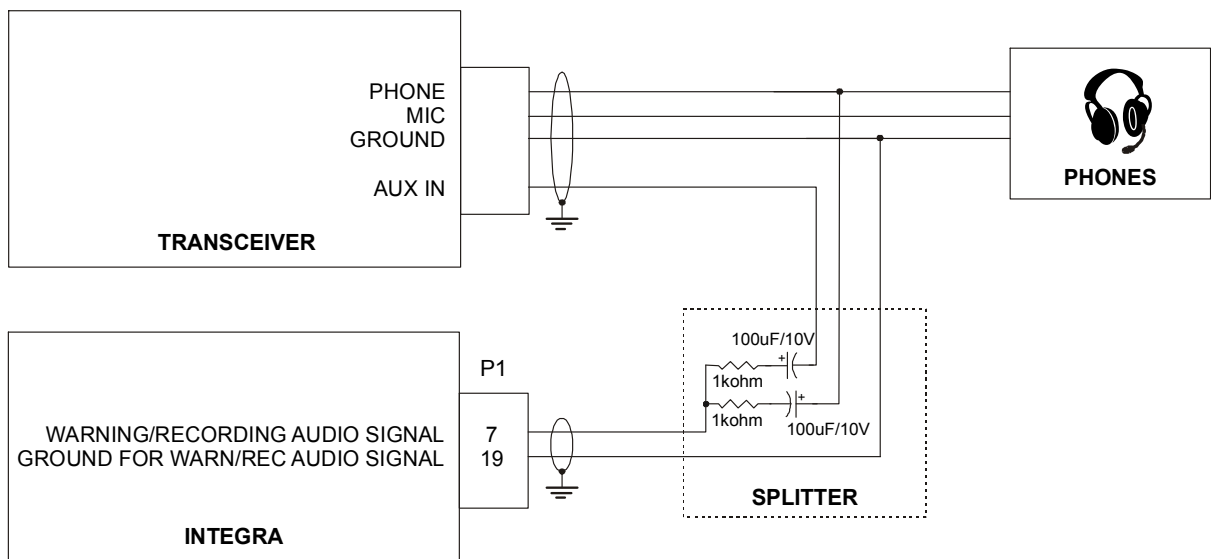
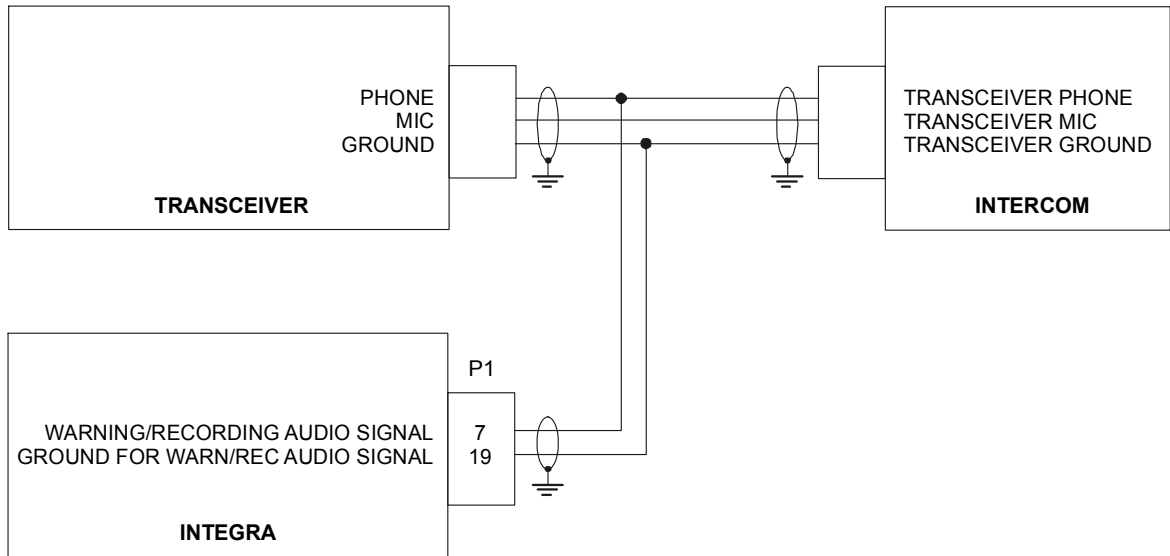

7 INTEGRA Data Sharing

New Integra Glass Cockpits with 9" displays have same software architecture as Integra Glass Cockpits with 7" displays. This means that functionality is identical for both mentioned product lines. The product lines are fully compatible with each other. Practically this means that for example EFIS TL-6524 can be connected to TL-6760 via **iFamily®** BUS. Also HW solution for connection is identical for both product lines; the connectors are identical; so for example you can easily replace your TL-6624 with TL-6660 without any modification of harness.

Here is table describing part numbers for Integra Glass Cockpits:

Functionality	Part Number for Integra with 7" display	Part Number for Integra with 9" display
EFIS & EMS	TL-6624	TL-6660
EFIS	TL-6524	TL-6560
EMS	TL-6724	TL-6760
Remote Display	TL-6824	TL-6860

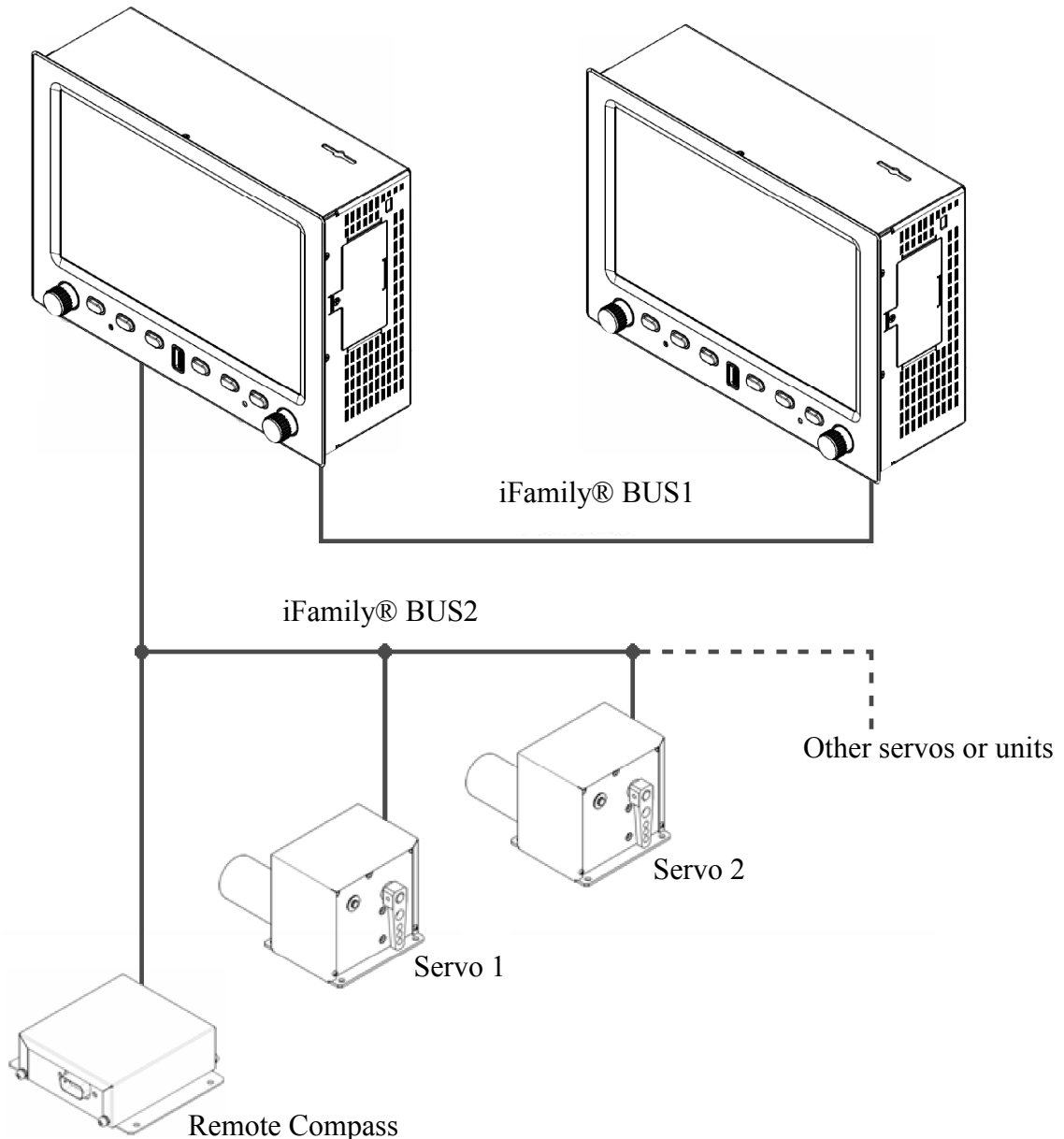

7.1 Explanation of Possible Connections

NOTE: This section does not contain all possible connections. Introduction of new Integra Glass Cockpits with 9” displays to market bring many new possible connections.

Here are a few Instrument connection Possibilities

If you connect TL-6524 with TL-6724 you will be able to share the screen data between the two instruments

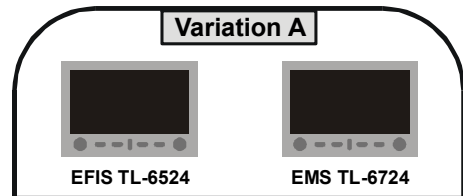

If you connect TL-6524 with TL-6824 you will be able to read the same data on TL-6824 as you have on TL-6524

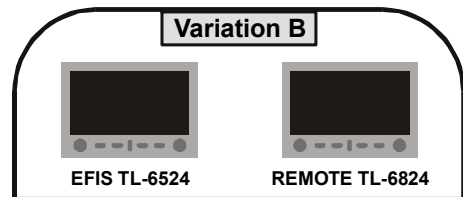

If you connect TL-6724 with TL-6824 you will be able to read the same data on TL-6824 as you have on TL-6724

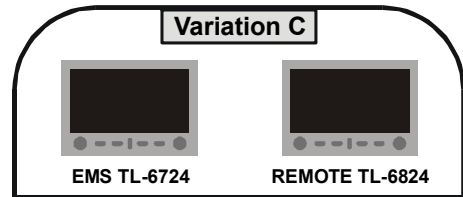

If you connect TL-6624 with TL-6824 you will be able to read the same data on TL-6824 as you have on TL-6624

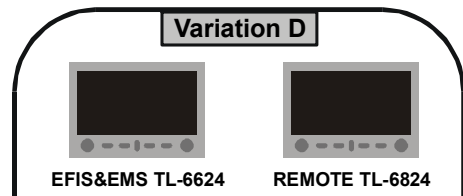

7.2 Back up System Recommendation

NOTE: This section does not contain all possible connections. Introduction of new Integra Glass Cockpits with 9” displays to market bring many new possible connections.

We recommend this configuration for safe panel system redundancy: **TL 6524 and 6624**

In the case of instrument failure flight information will be available on the second instrument

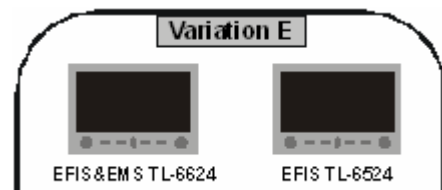

7.3 INTEGRA Connector Location

It is necessary to terminate the bus at both ends with 120 Ohms. The resistors are there to prevent reflections of communication on the bus.

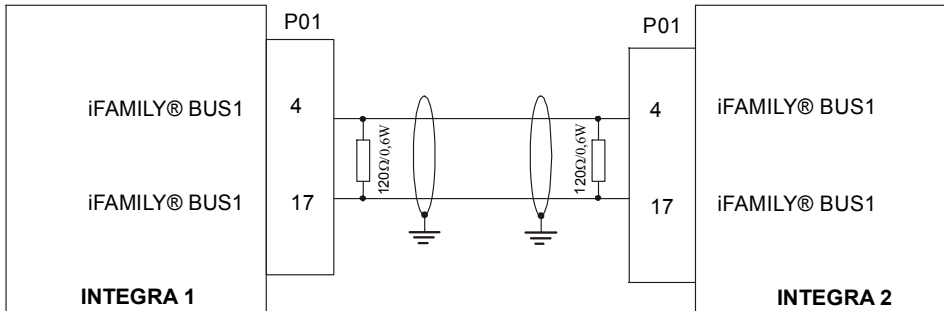



⚠ CAUTION: A twisted pair cable must be used to connect instruments or equipment within the iFamily® CAN BUS system.

⚠ CAUTION: Do not interconnect the CAN BUS within one Integra.

8 Sensor Connection

The Integra can be connected only to the approved sensors, see the Integra accessories list on our website.

 **CAUTION:** Other sensors can damage the Integra, therefore do not connect them to the Integra under any circumstances!

 **NOTE:** Sensors intended for quantities measurement that have resistive output and are connected to the Integra cannot be shared with any other analogue or digital instrument to duplicate the displayed value.

9 TL electronic Equipment Connection

9.1 Remote Compass

TL elektronik Remote Compass is source for the heading data.

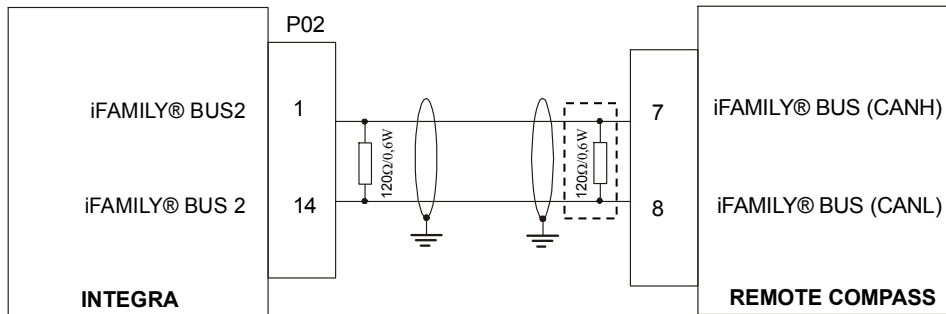

9.2 Servo

TL elektronik Servo is necessary equipment to use autopilot.

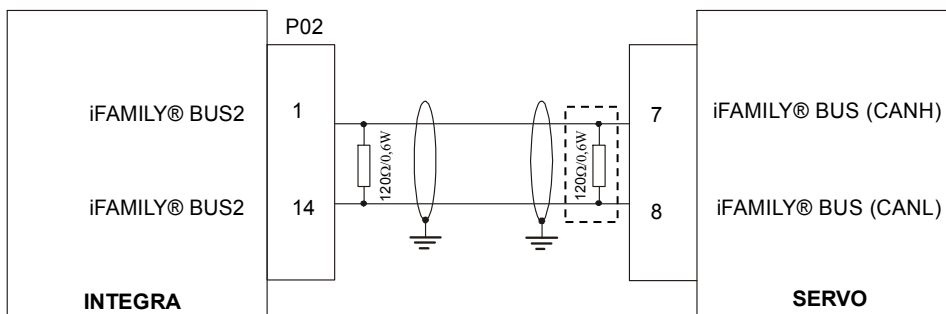

NOTE: It is necessary to terminate the bus at both ends with 120 ohm resistors. The resistors are there to prevent reflections of communication on the bus. On one bus there is possible to have only two resistors!

9.3 Video Camera

Visual information provided by video camera is useful especially in case of towing a glider. Video camera is not directly connected to the Integra, it uses TL-elektronik Video server. This solution enables connect up to four video cameras. Cycling through views of cameras is controlled by the Integra buttons. Check operation and pictures of displayed Towing screens of the Integra in User Manual (section Integra Menu-Other Setting).

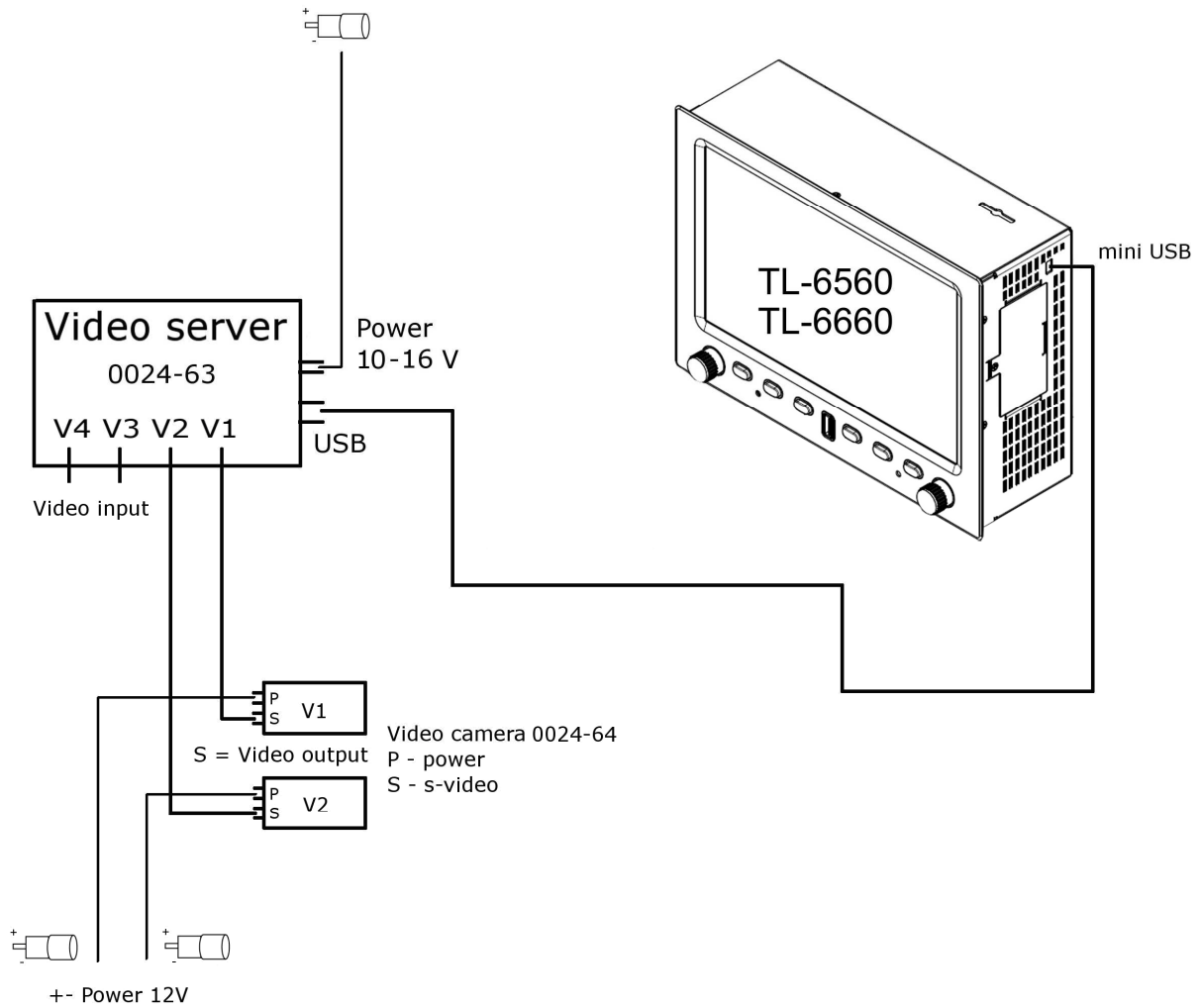

10 Other Equipment Connection

NOTE: There could be only one external equipment connected to each port.

10.1 CO Guardian

We recommended as CO Guardian type: 452, 452R, 353 or 353R. Following diagrams are just for these types.

Diagram for connection to COM1

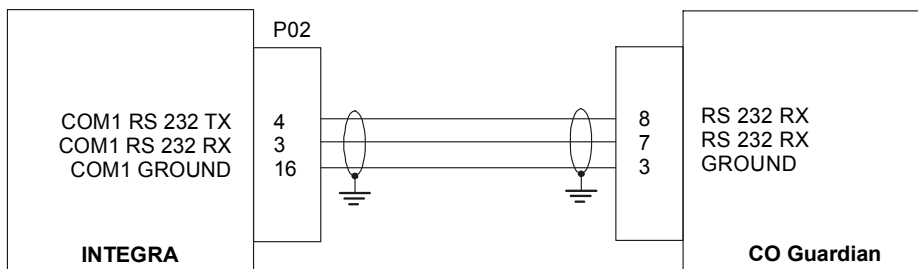
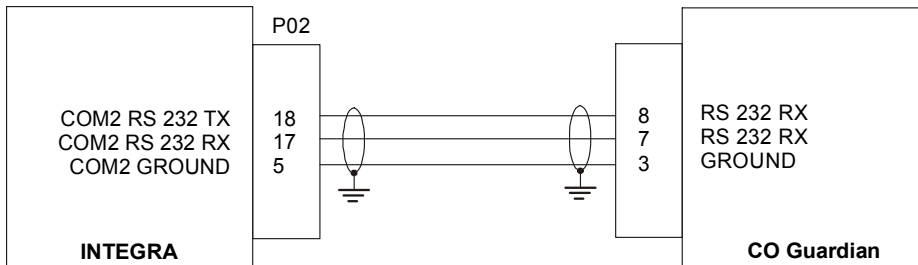

Diagram for connection to COM2



10.2 Garmin SL – 30

The SL30 can be used as a VOR, localizer, or ILS (localizer + glide slope) source for the HSI.

Diagram for connect to COM1

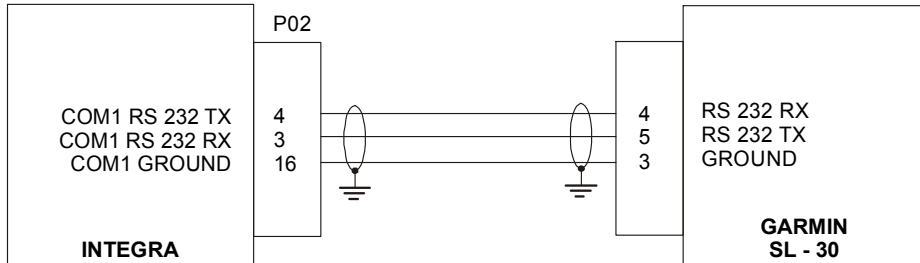
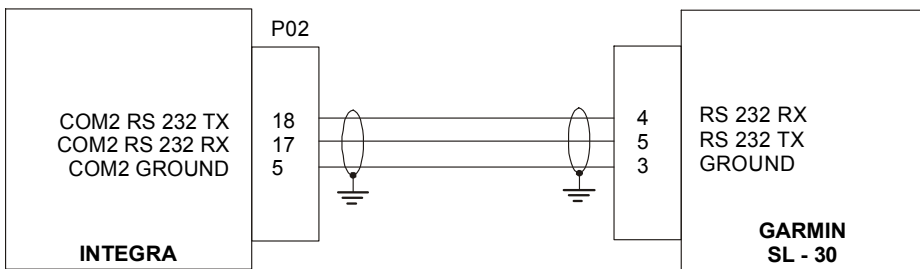

Diagram for connect to COM2



10.3 Transponder

Transponder Connection

PIN 8	PIN 9	PIN10	PIN11	PIN12	PIN20	PIN21	PIN22	PIN23	PIN 24	
A1	A2	A4	B1	B2	B4	C1	C2	C4	STROBE	
14	13	15	19	17	16	21	18	20	Disable	ARC RT359A/459A/859A
16	15	14	17	19	18	22	21	20	Disable	BECKER ATC 2000/3401
1	2	3	14	15	16	17	18	19	Disable	BECKER ATC 4401
4	6	8	9	10	11	3	5	7	Disable	BENDIX TRP-2060/2061/660
A	B	C	D	E	F	H	J	K	Disable	BENDIX TR541A/641B
12	10	7	6	5	4	8	11	9	Disable	COLLINS TDR-950/950L
7	5	3	12	13	14	8	6	4	2	EDO-AIRE RT-777
3	5	6	9	11	12	10	4	7	Disable	GARMIN 320/320A/327
4	5	6	7	8	9	10	11	12	3	GENAVE BETA 5000
6	7	9	4	1	2	3	8	10	Disable	KING KT76/78
M	K	J	E	C	B	D	L	H	Disable	KING KT76A/78A/76C/79
G	H	J	K	L	M	P	R	S	Disable	KING 750A
6	7	8	9	10	11	12	13	14	5	KING KT75
9	10	11	12	13	17	18	19	20	Disable	MICROAIR T2000
7	6	8	12	10	9	14	11	13	5	NARCO AT50/50A/150
2	4	8	9	10	11	1	3	5	12	NARCO AT5/6/6A
7	6	13	9	10	11	14	16	12	19	RADAIR 250
5	17	16	15	2	14	3	4	18	12	TERRA TRT250/250D
13	31	12	33	14	32	16	34	15	Disable	UPS/APPLLO SL70
K	C	W	T	L	D	P	F	Z	Disable	WILCOX 1014A
2	4	5	7	9	10	8	3	6	Disable	GARMIN GTX 328

10.4 GPS

The GPS can be used as a data source for the EFIS, HSI, and Fuel pages, as well as TL-elektronik’s EFIS-based Autopilot.

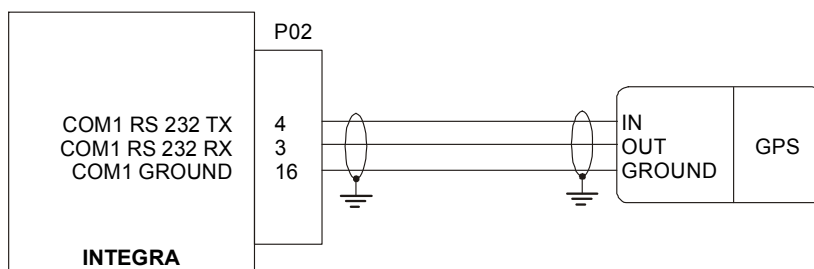

10.5 Other compatible equipment

Notice Sensor Configuration is detailed in the Configuration Manual.

- ⓘ NOTE:** Be sure that the external equipment shares a common ground with the INTEGRA. If your GPS is battery powered, and not normally connected to aircraft ground, you must connect the ground pin on its serial output to a ground common to the INTEGRA.

11 Conclusion

INSTRUCTIONS FOR RETURN

If none of the above sections have helped resolve an ongoing issue with your INTEGRA, please call TL electronic at +420 495 48 23 93 to discuss the issue with Technical Support.

In case the issue cannot be resolved, we will provide you with an RMA number to use when shipping the INTEGRA to us. If your unit is still under warranty, the repairs will be performed and the INTEGRA will be returned promptly. If your warranty has expired, the TL electronic representative will make arrangements with you and make you fully aware of the costs before proceeding with the repair.

While TL electronic makes every effort to save and restore your unit's settings and calibrations, we cannot guarantee that this will happen. Please note that after you receive your unit back from TL electronic with a factory calibration, the heading display on the INTEGRA may be inaccurate once re-installed in your aircraft.